



GENERAL SAFETY	1-1	SPECIAL TOOLS	1-7
SERVICE RULES	1-1	WIRING DIAGRAM	1-9
MODEL IDENTIFICATION	1-2	CABLE & HARNESS ROUTING	1-10
SPECIFICATIONS	1-3	MAINTENANCE SCHEDULE	1-12
TORQUE VALUES	1-5	EMISSION CONTROL SYSTEM	1-13

GENERAL SAFETY

WARNING

If the engine must be running to do some work, make sure the area is well-ventilated. NEVER run the engine in a closed area. The exhaust contains poisonous carbon monoxide gas.

WARNING

Gasoline is extremely flammable and is explosive under certain conditions. Do not smoke or allow flames or sparks in your working area.

WARNING

- *The battery electrolyte contains sulfuric acid. Protect your eyes, skin and clothing. In case of contact, flush thoroughly with water and call a doctor if electrolyte gets in your eyes.*
- *The battery generates hydrogen gas which can be highly explosive. Do not smoke or allow flames or sparks near the battery, especially while charging it.*

SERVICE RULES

1. Use genuine HONDA or HONDA-recommended parts and lubricants or their equivalent. Parts that do not meet HONDA's design specifications may damage the motorcycle.
2. Use the special tools designed for this product to avoid damage and incorrect assembly.
3. Use only metric tools when servicing this motorcycle. Metric bolts, nuts, and screws are not interchangeable with English fasteners.
4. Install new gaskets, O-rings, cotter pins, lock plates, etc. when reassembling.
5. When torquing bolts or nuts, begin with the larger-diameter or inner bolt first, and tighten to the specified torque diagonally in 2-3 steps, unless a particular sequence is specified.
6. Clean parts in non-flammable or light flash point cleaning solvent upon disassembly.
7. Lubricate any sliding surfaces before reassembly.
8. When installing a new oil seal, lubricate the sealing lip with grease. If an oil seal and related parts have been cleaned, lubricate the lip of the oil seal with grease.
9. After reassembly, check all parts for proper installation and operation.

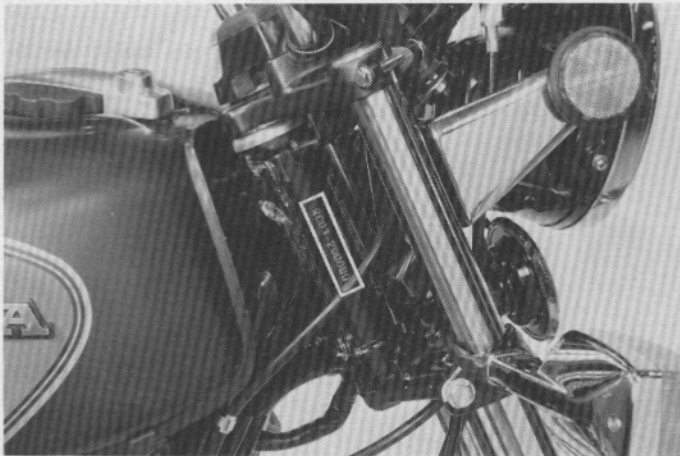
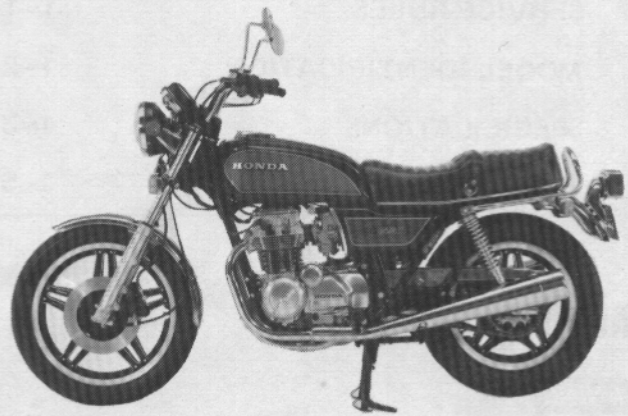
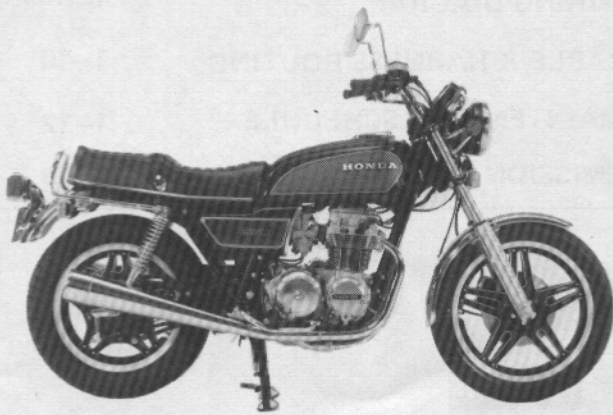
MODEL IDENTIFICATION

The frame serial number is stamped on the right side of the steering head.

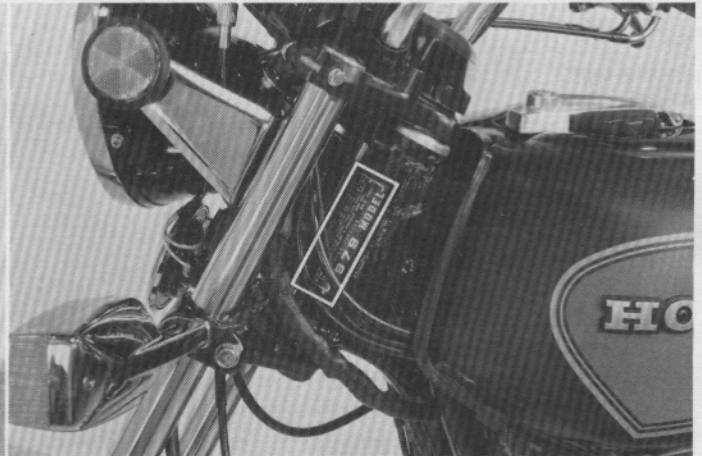

The vehicle identification number (VIN) is on the left side of the steering head.

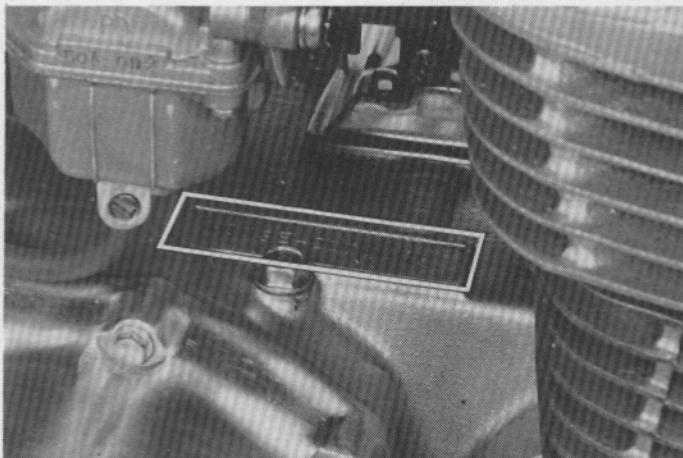

The engine serial number is stamped on top of the crankcase.

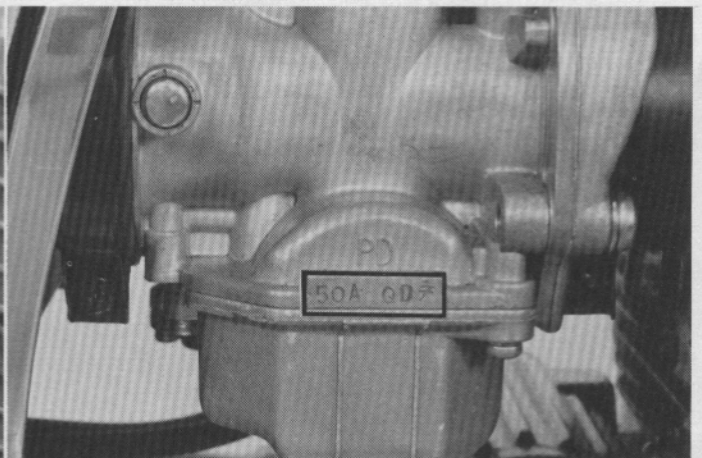

The carburetor identification number is on the right side of the carburetor body.



SPECIFICATIONS

ITEM		SPECIFICATION
DIMENSIONS	Overall length	2,170 mm (85.4 in)
	Overall width	850 mm (33.5 in)
	Overall height	1,175 mm (46.3 in)
	Wheelbase	1,430 mm (56.3 in)
	Seat height	800 mm (31.5 in)
	Foot peg height	325 mm (12.8 in)
	Ground clearance	160 mm (6.3 in)
	Dry weight	196 kg (431.2 lb)
FRAME	Type	Double cradle
	Front suspension, travel	Telescopic fork 142 mm (5.6 in)
	Rear suspension, travel	Swing arm 77 mm (3.0 in)
	Front tire size	3.50H19 (4PR)
	Rear tire size	4.50H17 (4PR)
Cold tire pressures	Up to 90 kg (200 lbs) load	Front Rear
	Up to vehicle capacity load	Front Rear
	Front brake, lining swept area	Disc brake, 282 cm ² (43.71 sq in)
	Rear brake, lining swept area	Internal expanding shoes, 218 cm ² (33.79 sq in)
	Fuel capacity	18 liters (4.8 US gal)
	Fuel reserve capacity	3.5 liters (0.9 US gal)
	Caster angle	27°30'
	Trail	105 mm (4 in)
	Front fork oil capacity	170 cc (5.7 ozs) 150 cc (5.0 ozs) at draining
ENGINE	Type	Air cooled 4-stroke
	Cylinder configuration	Vertical in-line four
	Bore and stroke	59.8 x 55.8 mm (2.354 x 2.197 in)
	Displacement	627 cc (38.2 cu in)
	Compression ratio	9.0 : 1
	Valve train	Silent chain driven OHC
	Oil capacity	3.5 liters (3.7 US qt) 3.0 liters (3.2 US qt) after draining
	Lubrication system	Wet sump
	Air filtration	Paper
	Cylinder compression	12.0 ± 2.0 kg/cm ² (170 ± 28 psi)
	Intake valve	Opens 5° (BTDC) at 1 mm lift, 58° (BTDC) at 0 lift Closes 35° (ABDC) at 1 mm lift, 127° (ABDC) at 0 lift
	Exhaust valve	Opens 40° (BBDC) at 1 mm lift, 121° (BBDC) at 0 lift Closes 5° (ATDC) at 1 mm lift, 65° (ATDC) at 0 lift
	Valve clearance	IN: 0.05 mm (0.002 in) EX: 0.08 mm (0.003 in)
	Engine weight	70 kg (154.4 lb)
	Idle speed	1,050 ± 100 rpm
CARBURETION	Carburetor type	Piston valve, 26 mm (1.0 in)
	Identification number	PD50A
	Pilot screw	Refer to page 4-15
	Float level	12.5 mm (0.50 in)



ITEM																				
DRIVE TRAIN	Clutch Transmission Primary reduction Gear ratio I Gear ratio II Gear ratio III Gear ratio IV Gear ratio V Final reduction Gear shift pattern Drive chain	Wet, multi-plate 5-speed constant-mesh 2.737 2.500 1.722 1.333 1.074 0.885 2.500 (16/40) Left foot operated return system RK50NK or DID 50HDK, 102 links																		
ELECTRICAL	Ignition Ignition timing "F-I" mark Full advance Starting system Generator Battery capacity Spark plug () CANADA model Spark plug gap Firing order Fuse	Transistorized 10° BTDC at 1,050 rpm idle 28°30' BTDC/2.725 rpm Starting motor only Three phase A.C. generator 0.26 kw/5,000 rpm 12V-12AH <table border="1" style="width: 100%; text-align: center;"> <thead> <tr> <th colspan="2">For cold climate below 5°C (41°F)</th> <th colspan="2">Standard</th> <th colspan="2">For extended high speed driving</th> </tr> <tr> <th>ND</th> <th>NGK</th> <th>ND</th> <th>NGK</th> <th>ND</th> <th>NGK</th> </tr> </thead> <tbody> <tr> <td>X22ES-U</td> <td>D7EA</td> <td>X24ES-U (X24ESR -U)</td> <td>D8EA (D8ES -L)</td> <td>X27ES-U</td> <td>D9EA</td> </tr> </tbody> </table> 0.6-0.7 mm (0.024-0.028 in) 1-2-4-3 10A, 30A	For cold climate below 5°C (41°F)		Standard		For extended high speed driving		ND	NGK	ND	NGK	ND	NGK	X22ES-U	D7EA	X24ES-U (X24ESR -U)	D8EA (D8ES -L)	X27ES-U	D9EA
For cold climate below 5°C (41°F)		Standard		For extended high speed driving																
ND	NGK	ND	NGK	ND	NGK															
X22ES-U	D7EA	X24ES-U (X24ESR -U)	D8EA (D8ES -L)	X27ES-U	D9EA															
LIGHTS	Headlight (high/low beam) Tail/stoplight Turn signal (front/rear) Speedometer Tachometer Neutral indicator Turn signal indicator High beam indicator	65/50W sealed beam 3/32 cp SAE NO. 1157 32/32 cp SAE NO. F. 1034, R. 1073 2 cp SAE NO. 57 2 cp SAE NO. 57 2 cp SAE NO. 57 2 cp SAE NO. 57 2 cp SAE NO. 57																		



TORQUE VALUES

ENGINE

Item	Q'ty	Thread Dia mm	Torque kg-m (ft-lb)	Remarks
Breather cover	6	6	0.8-1.2 (6-9)	
Tachometer gear holder	1	6	0.8-1.2 (6-9)	
Cylinder head cover	20	6	0.8-1.2 (6-9)	
Valve adjusting nut	8		1.2-1.6 (9-12)	
Rocker arm shaft cotter pin	4	6	1.0-1.4 (7-10)	
Rocker arm shaft cap bolt	4		0.8-1.2 (6-9)	
Cylinder head bolt	12	8	2.4-3.0 (17-22)	Apply molybdenum disulfided grease to the threads and under-side of bolts.
	2	6	1.0-1.4 (7-10)	
Spark plug	4		1.2-1.6 (9-12)	
Cam sprocket	2	7	1.4-1.8 (10-13)	
Cam chain tensioner	2	6	1.0-1.4 (7-10)	Apply molybdenum disulfided grease to the threads and under-side of bolts.
Crankcase	13	8	2.2-2.6 (16-19)	
Oil gallery cap	2		1.0-1.4 (7-10)	
A.C. generator	1	10	5.0-6.0 (36-43)	
Spark advancer	1		0.8-1.2 (6-9)	
Connecting rod	8		2.4-2.8 (17-20)	
Starting clutch	3	6	1.2-1.6 (9-12)	Apply locking agent to the threads.
Clutch	1	20	4.7-5.3 (34-38)	
Oil filter case	1		2.7-3.3 (20-24)	
Oil pressure switch	1		1.0-2.0 (7-15)	Apply liquid sealant
Neutral switch rotor	1		0.6-1.0 (4-7)	
Primary chain tensioner	1	6	1.0-1.4 (7-10)	
Primary chain nozzle	1	6	0.8-1.2 (6-9)	
Gearshift return pin	1		2.3-2.7 (17-20)	
Throttle cable adjusting lock nut	2		0.6-0.8 (4-6)	

CHASSIS

Item	Q'ty	Thread Dia mm	Torque kg-m (ft-lb)	Remarks
Steering stem nut	1	24	8.0-12.0 (58-87)	
Steering handlebar	4	8	2.8-3.2 (20-23)	
Front fork top bridge	2	7	0.9-1.3 (7-9)	
Front fork cap bolt	2		2.0-3.0 (15-22)	
Steering stem	2	10	3.0-4.0 (22-29)	
Front axle holder	4	8	1.8-2.5 (13-18)	
Front axle nut	1	12	5.5-6.5 (40-48)	
Front brake disc	5	8	2.7-3.3 (20-24)	UBS
Brake hose bolt	2	10	2.5-3.5 (18-25)	
Front brake caliper carrier	2	10	3.0-4.0 (22-29)	
Front brake caliper A	2	10	3.0-4.0 (22-29)	
Rear axle	1	18	8.0-10.0 (58-72)	
Final driven sprocket	4	12	8.0-10.0 (58-72)	UBS
Swing arm pivot nut	1	14	6.0-7.0 (43-51)	
Rear brake torque link	1	8	1.8-2.5 (13-18)	
Rear shock absorber	4	10	3.0-4.0 (22-29)	
Engine hanger bolt	5	10	3.0-4.0 (22-29)	
	1	12	8.0-10.0 (58-72)	
	8	8	2.6-3.2 (19-23)	
Foot peg	1	10	3.0-4.0 (22-29)	
Gearshift pedal	1	6	0.8-1.2 (6-9)	
Brake fluid reservoir cap	4	4	0.1-0.2 (0.7-1.4)	

Torque specifications listed above are for the most important tightening points. If a torque specification is not listed, follow the standards given below.

STANDARD TORQUE VALUES

Type	Torque kg-m (ft-lb)	Type	Torque kg-m (ft-lb)
5 mm bolt, nut	0.45-0.6 (3.5-4.5)	5 mm screw	0.35-0.5 (2.5-3.6)
6 mm bolt, nut	0.8-1.2 (6-9)	6 mm screw	0.7-1.1 (5-8)
8 mm bolt, nut	1.8-2.5 (13-18)	6 mm flange bolt, nut	1.0-1.4 (7-10)
10 mm bolt, nut	3.0-4.0 (22-29)	8 mm flange bolt, nut	2.4-3.0 (17-22)
12 mm bolt, nut	5.0-6.0 (36-43)	10 mm flange bolt, nut	3.0-4.0 (22-29)



SPECIAL TOOLS

Tool	Part No.	Q'ty	Ref. page
Valve adjusting wrench	07908-3230000	1	3-6
Spark plug wrench	07909-3000000	1	3-3
Snap ring pliers	07914-3230001	1	15-6
Hex wrench (6 mm)	07917-3230000	1	13-17, 13-20
Sliding hammer shaft	07936-3740100	1	10-3
Sliding hammer weight	07945-3000500	1	10-3
Ball race remover	07953-3330000	1	13-23
Piston ring compressor	07954-3740000	2	7-8
Piston base	07958-2500001	2	7-8
Torx driver bit	07703-0010200	1	11-4, 11-15
Bearing driver attachment	07946-3290000	1	13-24, 14-8
Valve guide reamer	07984-2000000	1	6-11, 6-12
Carburetor throttle wrench	07908-4220100	1	3-10
Carburetor pilot screw wrench	07908-4220201	1	4-15
Cylinder head bolt wrench	07906-3230000	1	6-9, 6-15
Oil pressure gauge attachment	07510-4220100	1	2-3
Bearing driver attachment	07947-6710100	1	11-16, 13-24

COMMON TOOLS

Tool	Part No.	Q'ty	Alternate Tool Part No.	Ref. Page
Float level gauge	07401-0010000	1		4-5
Retainer wrench (A)	07710-0010100	1	Bearing retainer wrench 07910-2830000	14-4
Retainer wrench (B)	07710-0010200	1	Bearing retainer wrench 07910-3230101	13-12, 13-14
Retainer wrench (C)	07710-0010300	1	Bearing retainer wrench 07910-3930000	14-4,
Retainer wrench body	07710-0010401			13-12, 13-14 14-4
Lock nut wrench socket (30 x 32 mm)	07716-0020400	1		13-22, 13-25
Lock nut wrench socket (26 x 30 mm)	07716-0020202	1		8-3, 8-7,
Extension bar	07716-0020500	1		8-3, 8-7 13-22, 13-25
Universal holder	07725-0010101	1		8-3, 8-7
Valve guide remover (5.5 mm)	07742-0010100	1	Valve guide driver 07942-3290100	6-12
Valve guide driver (B)	07742-0020200	1	Valve guide driver 07942-3290200	6-12
Bearing driver outer (42 x 47)	07746-0010300	1	Bearing driver 07945-3330100	13-14
Bearing driver outer (62 x 68)	07746-0010500	1	Bearing driver 07946-3600000	14-8
Bearing driver handle (C)	07746-0030100	1		11-12
Bearing driver inner (25 mm)	07746-0030200	1		11-12
Bearing driver pilot (15 mm)	07746-0040300	1		13-14
Bearing driver pilot (20 mm)	07746-0040500	1		14-8
Bearing driver pilot (22 mm)	07746-0041000	1		11-16
Bearing driver pilot (25 mm)	07746-0040600	1		14-8
Bearing driver handle (B)	07746-0020100	1		11-16
Rotor puller	07733-0020001	1		16-6
Front fork oil seal driver body	07747-0010100	1	Fork seal driver 07947-3290000	13-21
Front fork oil seal attachment (E)	07747-0010600	1		13-21
Bearing driver handle (A)	07749-0010000	1	Driver handle attachment 07949-6110000	11-16, 13-14, 13-24, 14-8
Valve spring compressor	07757-0010000	1	Valve spring compressor 07957-3290001	6-9, 6-14
Shock absorber compressor	07959-3290001	1		14-10, 14-11
Pin spanner	07702-0010000	1	Pin spanner 07902-2000000	13-22, 13-24



HONDA CB650

WIRING DIAGRAM

CB650

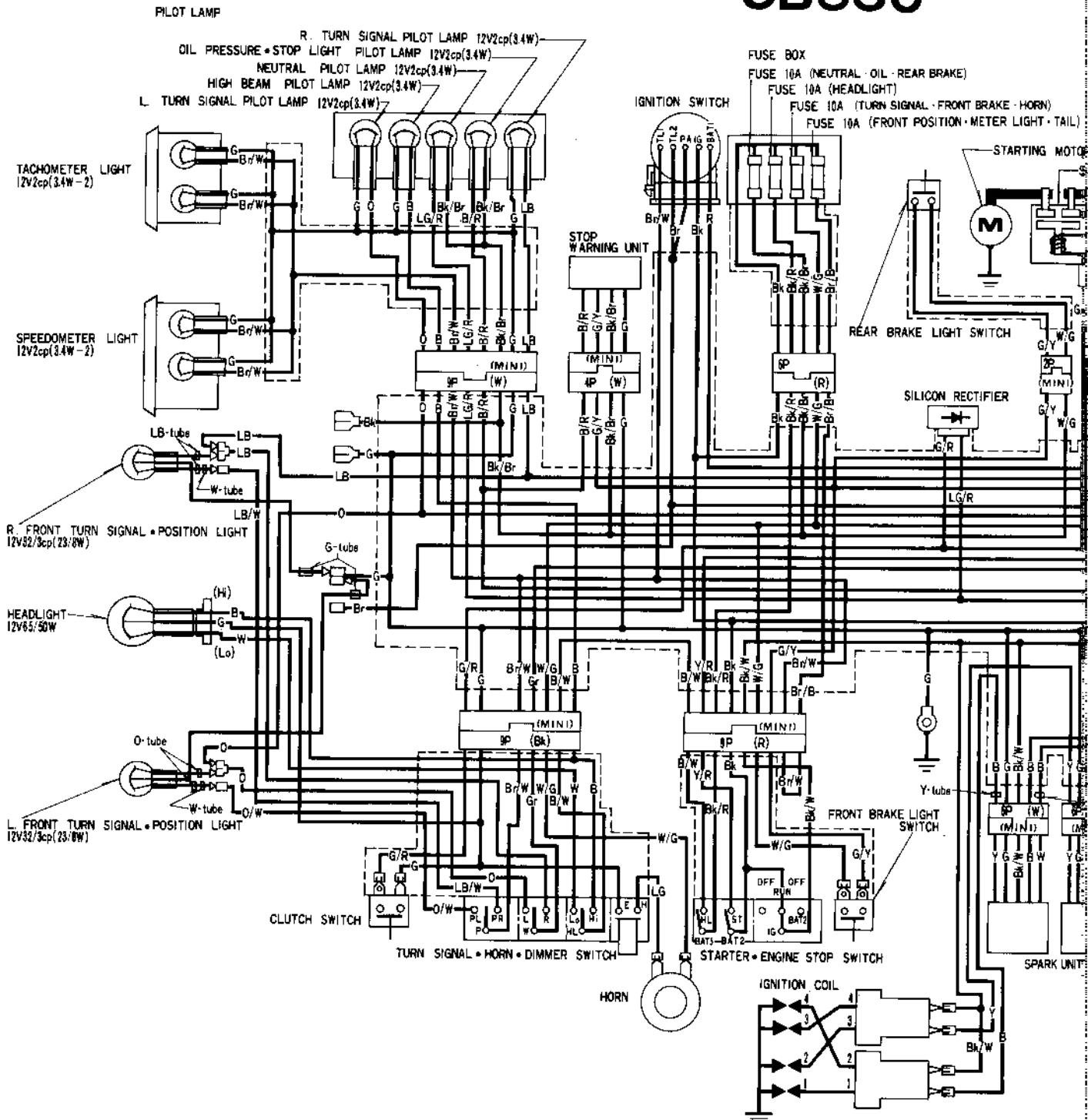

IGNITION SWITCH CONTINUITY

	BAT1	IG	TL1	TL2	P
OFF					
ON	○	○	○	○	
P	○				○

STARTER SWITCH CONTINUITY

	BAT3	HL	BAT2	ST
FREE	○	○		
PUSH			○	

ENGINE STOP SWITCH CONTINUITY

	BAT2	IG
OFF		
RUN	○	○
OFF		

TURN SIGNAL SWITCH CONTINUITY

	W	R	L	P	PR	PL
R	○				○	○
N					○	○
L			○			

DIMMER SWITCH CONTINUITY

	HL	Lo	Hi
Lo	○	○	
(N)	○	○	
Hi			○

HORN SWITCH CONTINUITY

	HO	E
FREE		
PUSH	○	○

CB650

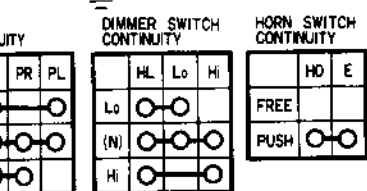
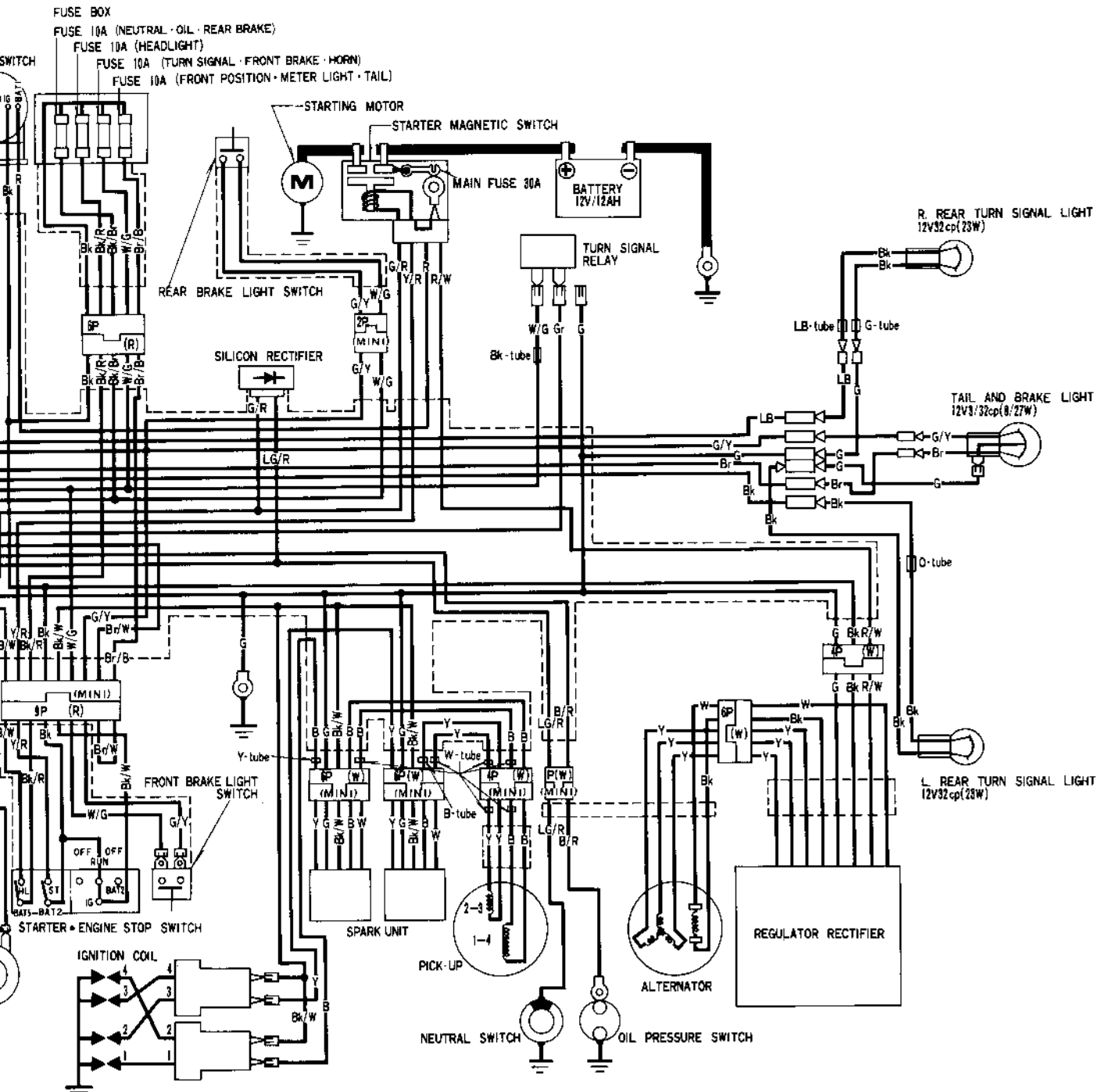

- Br Brown
- Bk Black
- W White
- LG Light Green
- R Red
- G Green
- Y Yellow
- B Blue
- Gr Grey
- LB Light Blue
- O Orange
- P Pink

0030Z-426-7700

GENERAL INFORMATION



HONDA
CB650

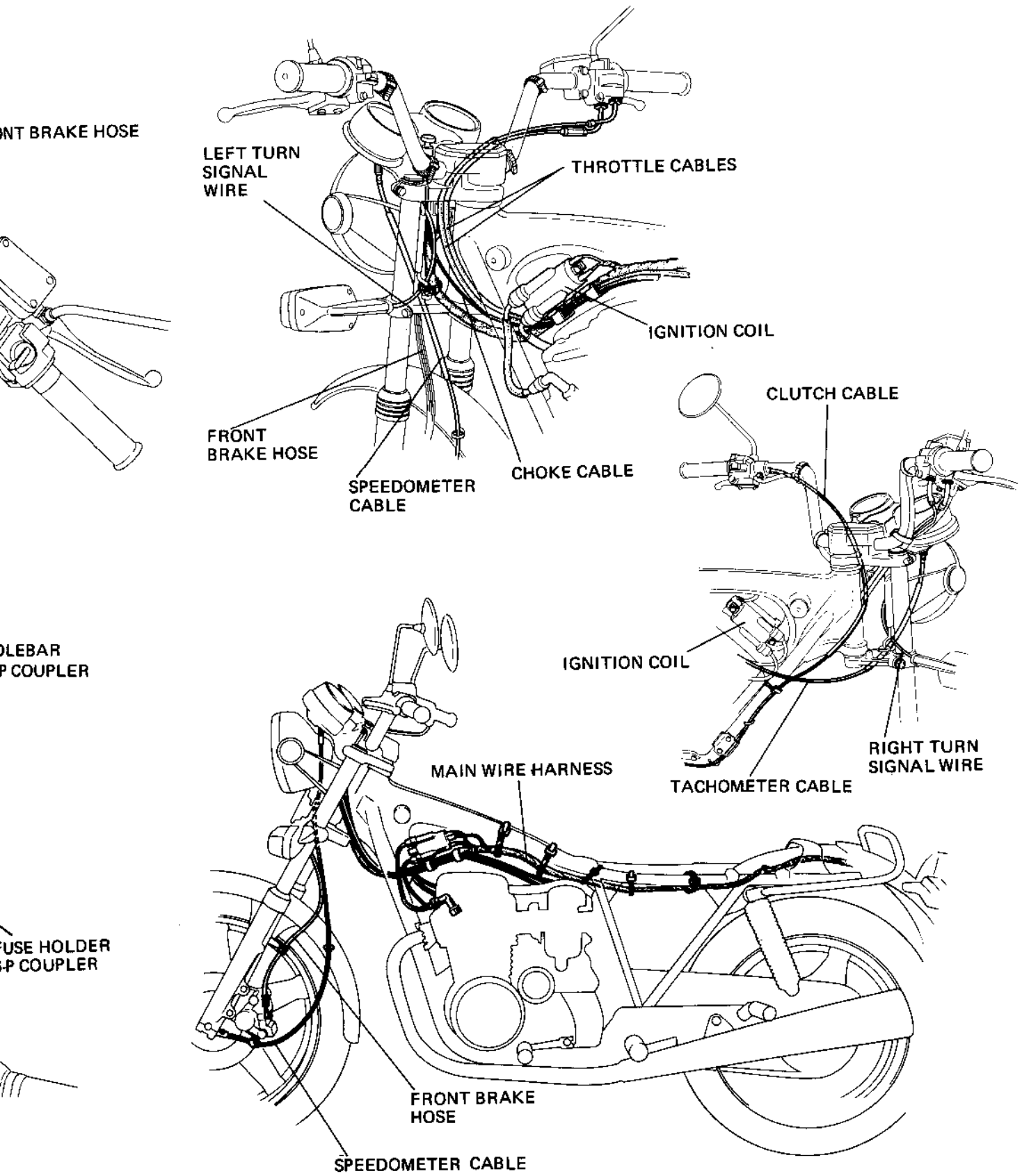

CABLE & HARNESS ROUTING

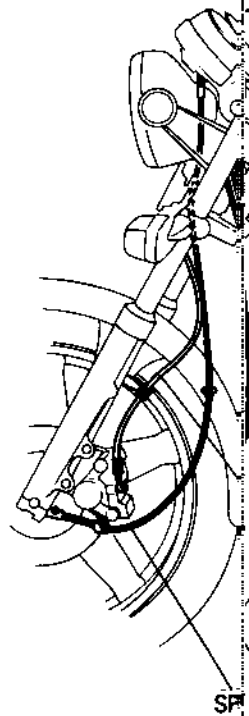
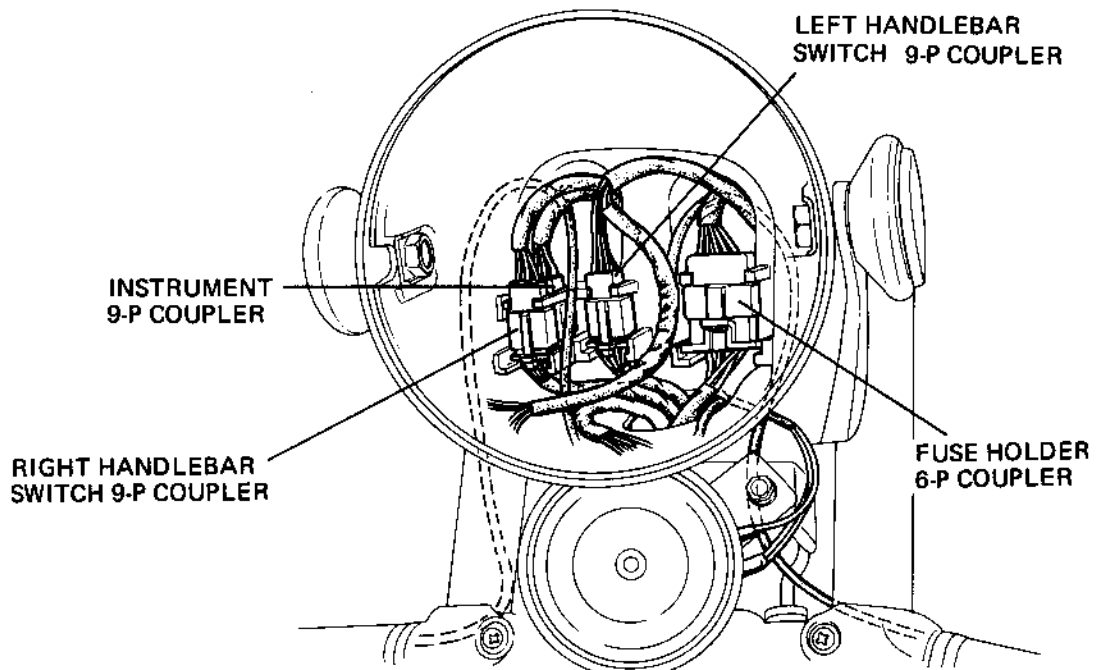
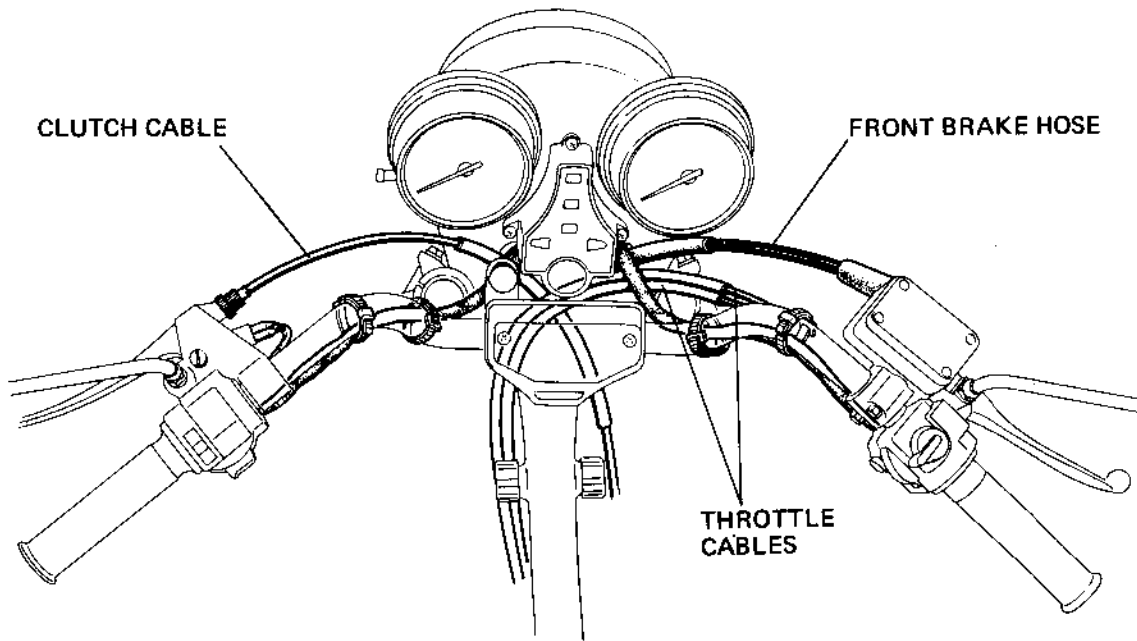

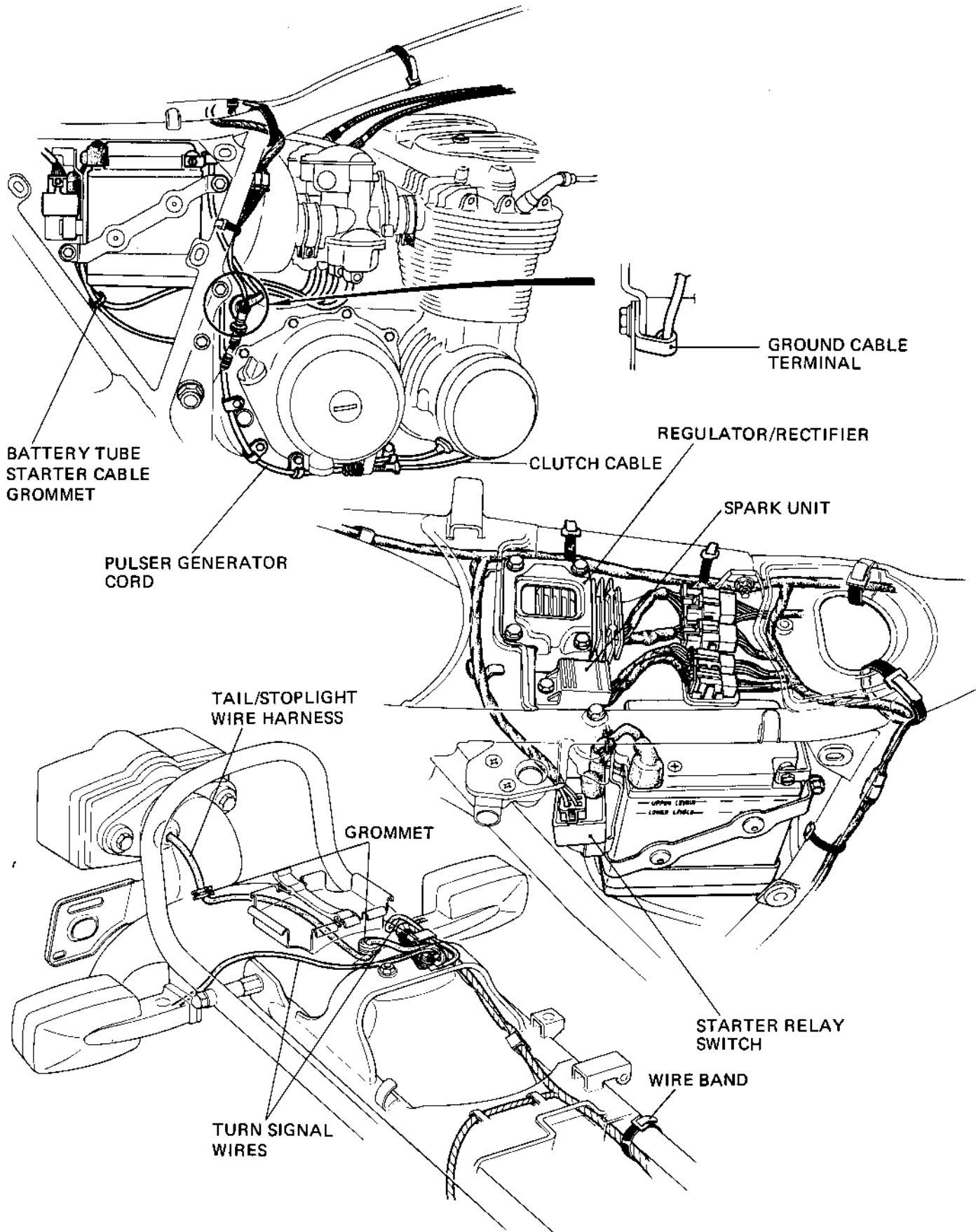



MAINTENANCE SCHEDULE

Perform the PRE-RIDE INSPECTION in the Owner's Manual at every maintenance period.

I : INSPECT, CLEAN, ADJUST, LUBRICATE, OR REPLACE IF NECESSARY.

C: CLEAN

R: REPLACE

A: ADJUST

L: LUBRICATE

	ITEM	FREQUENCY	WHICHEVER COMES FIRST	ODOMETER READING (NOTE 3)						Refer to
				EVERY	600 mi (1,000 km)	4,000 mi (6,400 km)	8,000 mi (12,800 km)	12,000 mi (19,200 km)	16,000 mi (25,600 km)	
EMISSION RELATED ITEMS	ENGINE OIL	YEAR	R	R	R	R	R	R	R	Page 2- 2
	ENGINE OIL FILTER	YEAR	R	R	R	R	R	R	R	Page 2- 2
	CRANKCASE BREATHER	NOTE 1		C	C	C	C	C	C	Page 3- 2
	AIR CLEANER	NOTE 2		C	R	C	R	C		Page 3- 3
	* FUEL LINES			I	I	I	I	I	I	Page 3- 3
	SPARK PLUGS			I	R	I	R	I		Page 3- 3
	* VALVE CLEARANCE			I	I	I	I	I	I	Page 3- 6
	* CAM CHAIN TENSION			A	A	A	A	A	A	Page 3- 7
	* THROTTLE OPERATION			I	I	I	I	I	I	Page 3- 7
	* CARBURETOR-CHOKE			I	I	I	I	I	I	Page 3- 8
	* CARBURETOR-SYNCHRONIZE			I	I	I	I	I	I	Page 3- 9
	* CARBURETOR IDLE SPEED			I	I	I	I	I	I	Page 3-11
NON-EMISSION RELATED ITEMS	DRIVE CHAIN	EVERY 1000 MI (1600 KM)								Page 3-12
	BATTERY	MONTH								Page 3-13
	BRAKE FLUID (FRONT)	MONTH / 2 YEARS								Page 3-13
	BRAKE PAD/SHOE WEAR									Page 3-14
	BRAKE SYSTEM									Page 3-14
	* BRAKE LIGHT SWITCH									Page 3-15
	* HEADLIGHT AIM									Page 3-15
	CLUTCH FREE PLAY									Page 3-16
	SIDE STAND									Page 3-17
	* SUSPENSION									Page 3-18
	* NUTS, BOLTS, FASTENERS									Page 3-19
** WHEELS									Page 3-19	
** STEERING HEAD BEARING									Page 3-19	

* SHOULD BE SERVICED BY AN AUTHORIZED HONDA DEALER, UNLESS THE OWNER HAS PROPER TOOLS AND SERVICE DATA AND IS MECHANICALLY QUALIFIED.

** IN THE INTEREST OF SAFETY, WE RECOMMEND THESE ITEMS BE SERVICED ONLY BY AN AUTHORIZED HONDA DEALER.

NOTES: (1) SERVICE MORE FREQUENTLY WHEN RIDING IN RAIN OR AT FULL THROTTLE. (U.S.A. ONLY)

(2) SERVICE MORE FREQUENTLY WHEN RIDING IN DUSTY AREAS.

(3) FOR HIGHER ODOMETER READINGS, REPEAT AT THE FREQUENCY INTERVAL ESTABLISHED HERE.



EMISSION CONTROL SYSTEM (USA only)

The CB650 is equipped with two Emission Control Systems.

EXHAUST EMISSION CONTROL SYSTEM

The exhaust emission control system is composed of a factory pre-set carburetor. NO adjustment should be made to the system except the idle speed.

CRANKCASE EMISSION CONTROL SYSTEM

The engine is equipped with a "Closed System" to prevent crankcase emissions from entering the atmosphere. Blow-by gas is returned to the combustion chamber through the air cleaner and carburetor. Liquids are collected in the storage tank.

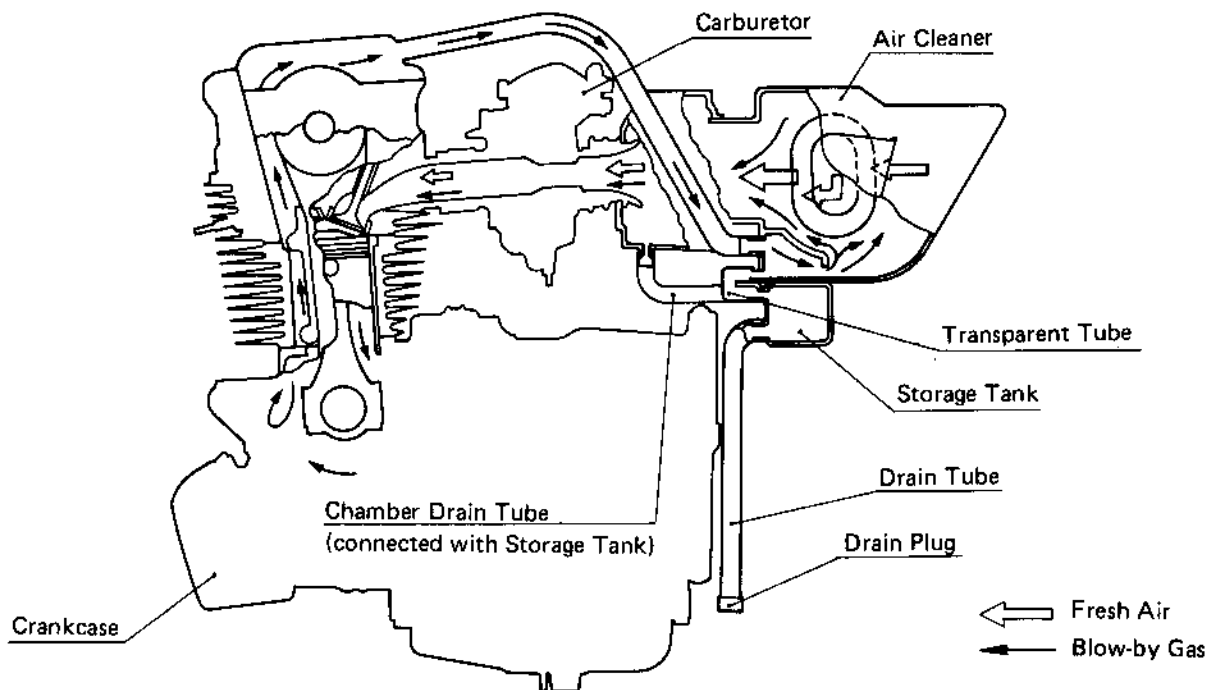

EMISSION CONTROL INFORMATION LABEL

An Emission Control Information Label is located on the frame as shown. It gives basic tune-up specifications.

