

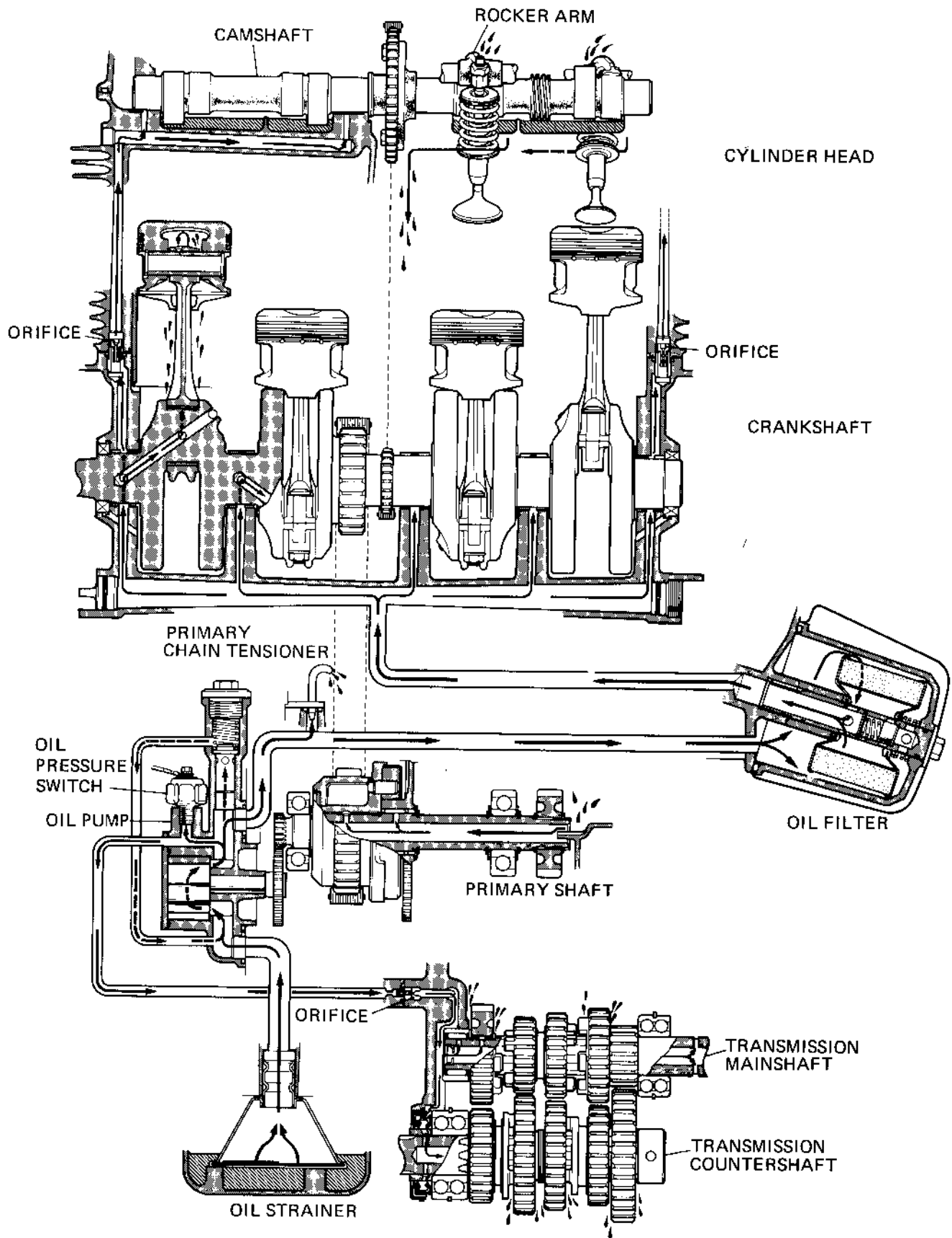

ENGINE LUBRICATION SYSTEM





SERVICE INFORMATION	2-1	OIL STRAINER CLEANING	2-3
TROUBLESHOOTING	2-1	OIL PRESSURE	2-3
<u>ENGINE LUBRICATION</u>		OIL PUMP	2-4
ENGINE OIL LEVEL	2-2	<u>CHASSIS LUBRICATION</u>	
ENGINE OIL & FILTER CHANGE	2-2	LUBRICATION POINTS	2-8

SERVICE INFORMATION

GENERAL INSTRUCTIONS

The oil strainer and oil pump maintenance and inspection can be accomplished without removing the engine.

SPECIAL TOOL

Oil Pressure Gauge Attachment 07510-4220100

TORQUE VALUES

Oil filter case	2.7-3.3 kg-m (20-24 ft-lb)
Oil pressure switch	1.0-2.0 kg-m (7-15 ft-lb)
Gearshift pedal	0.8-1.2 kg-m (6-9 ft-lb)

SPECIFICATIONS

Oil capacity	Approximately 3.0 liter (3.2 US qt) at oil change 3.5 liter (3.7 US qt) at engine assembly	
Recommended oil	HONDA 4-stroke oil or equivalent General, all temperature Alternates Above 15°C (60°F) -10° to 15°C (15° to 60°F) Above -10°C (15°F) Below 0°C (32°F)	API service classification - SE SAE 10W-40 SAE 30 SAE 20 or 20W SAE 20W-50 SAE 10W
Oil pump delivery	21.3-26.3 liter (22.5-27.8 US qt)/min at 3,000 rpm.	
Oil pressure (at oil pressure switch)	3.8-4.2 kg/cm ² (54-60 psi) at 3,000 rpm.	

TROUBLESHOOTING

Oil level too low

1. External oil leaks
2. Worn piston rings
3. Worn valve guide or seal

Oil contamination

1. Oil or filter not changed often enough
2. Head gasket faulty
3. Worn piston rings

Low oil pressure

1. Oil level low
2. Pressure relief valve stuck open
3. Plugged oil pick-up screen

4. Oil pump worn
5. External oil leaks

High oil pressure

1. Pressure relief valve stuck open
2. Plugged oil filter, gallery, or metering orifice
3. Incorrect oil being used

No oil pressure

1. Oil level low
2. Oil pump drive gear broken
3. Oil pump faulty
4. Internal oil leakage



ENGINE LUBRICATION

ENGINE OIL LEVEL

Start the engine and allow it to idle for a few minutes.

Stop the engine and support the motorcycle on the center stand. Wait a few minutes and check the oil level with the filler cap/dipstick. Do not screw in the cap when making this check. If the level is below the lower level on the dipstick, fill to the upper level mark. Check that the oil pressure warning light goes off when the engine starts. If it does not, check the brakelight circuit for a burnt out bulb, short or open circuit. If the brakelights operate properly, check the oil pump operation and/or oil circuit.

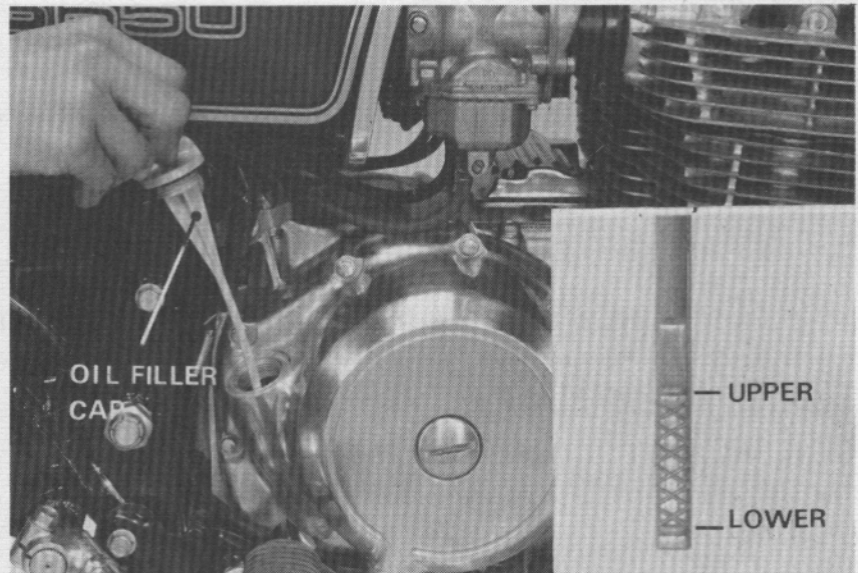

ENGINE OIL & FILTER CHANGE

Warm the engine to normal operating temperature.

Stop the engine.

Place the motorcycle on its center stand. Place a suitable container under the drain plug and oil filter.

Remove the oil filler cap, drain plug and oil filter bolt and drain the oil.

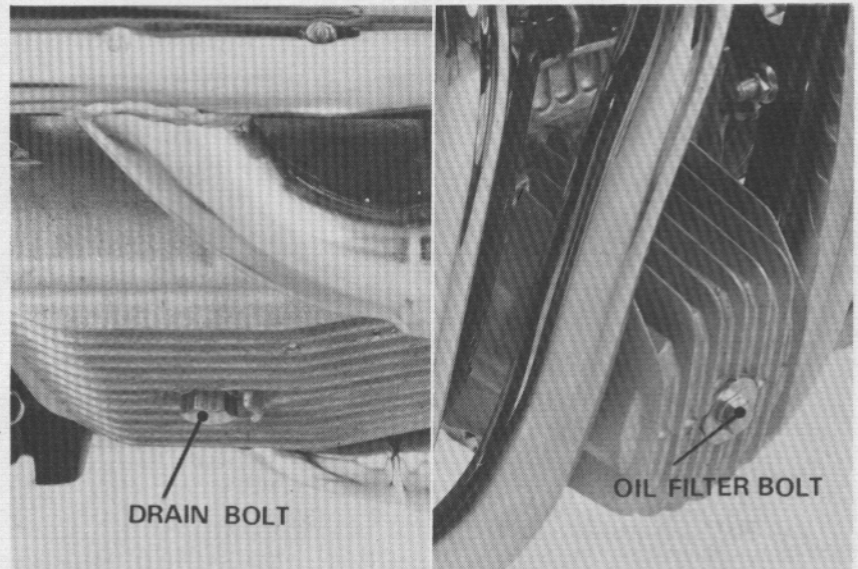

Check that the sealing washer on the drain plug and the O-rings on the oil filter bolt and oil filter are in good condition.

After draining is complete, replace the oil filter and install the oil filter bolt and drain plug.

Fill the crankcase with 3.0 liter (3.2 US qt) of the recommended oil.

Install the oil filler cap.

Start the engine and let it idle for 2-3 minutes. Check the oil level and add the recommended oil to the upper level.

Make sure that there are no oil leaks.

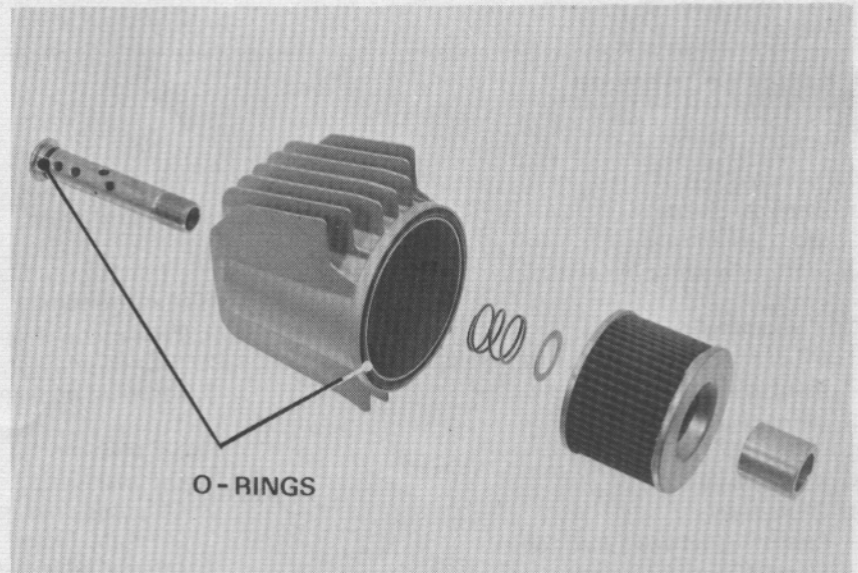



OIL STRAINER CLEANING

The oil strainer can be removed with the engine mounted in the frame.
Remove the oil filler cap and drain plug.
(See Engine Oil & Filter Change, page 2-2.)
Remove the oil pan bolts and oil pan.

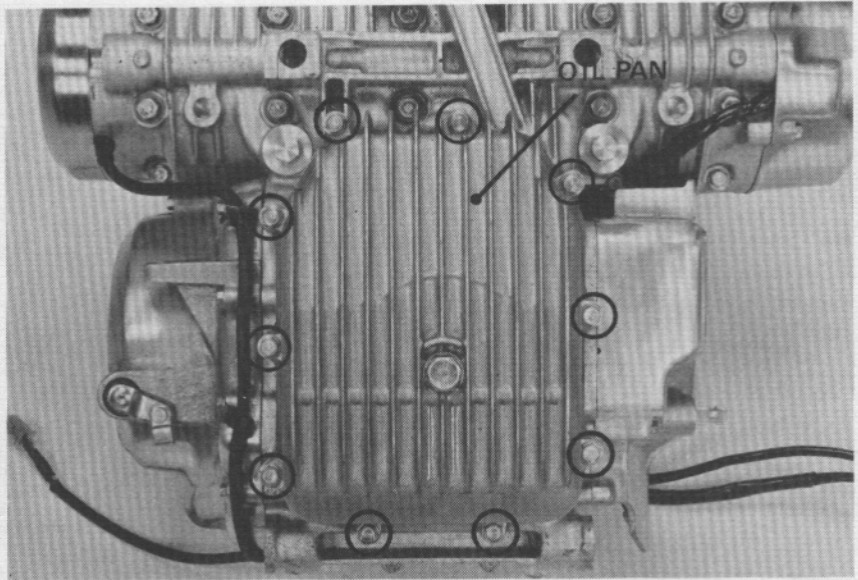

Remove and clean the oil strainer.
Install the oil strainer and oil pan.
Install the oil filter bolt, drain plug and fill the crankcase with the recommended oil. (See Engine Oil & Filter Change, page 2-2.)

NOTE

Align the slot in the strainer with the crankcase rib.

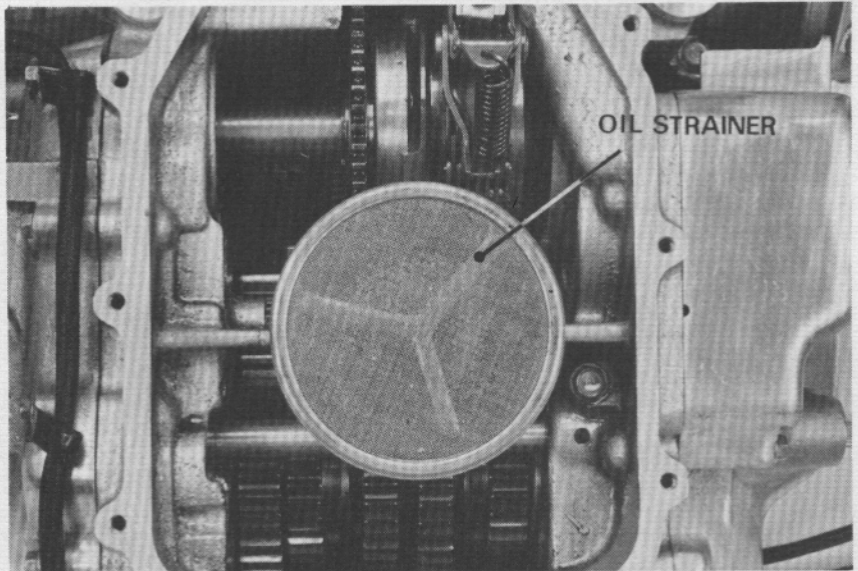
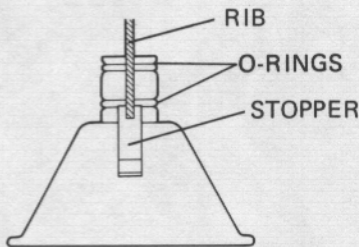

OIL PRESSURE

Warm the engine to normal operating temperature (approximately 80°C, 176°F).

Stop the engine.

Remove the left rear crankcase cover.

Disconnect the oil pressure switch wire.

Remove the oil pressure switch. (page 2-4)
Connect an oil pressure gauge to the pressure switch hole.

Check the oil level.

Start the engine and check the oil pressure at 3,000 rpm.

**STANDARD: 3.8–4.2 kg/cm² (54–60 psi)
at 3,000 rpm 80°C (176°F)**

Stop the engine.

Apply a liquid sealant to the pressure switch threads.

Install the switch and attach the wire.

Start the engine and check that the oil pressure warning light goes out. If the oil pressure warning light stays on, stop the engine immediately and determine the cause.

(Page 2-2 Engine Oil Level.)

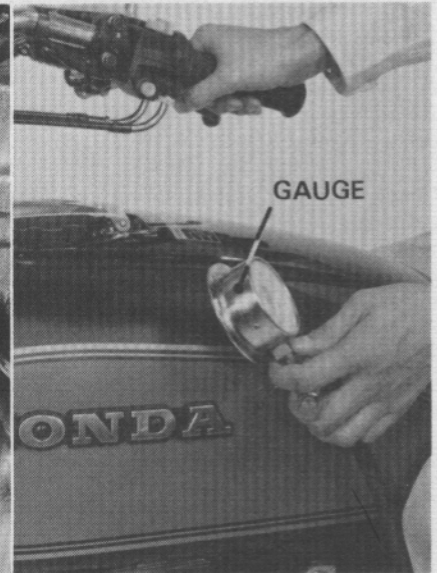
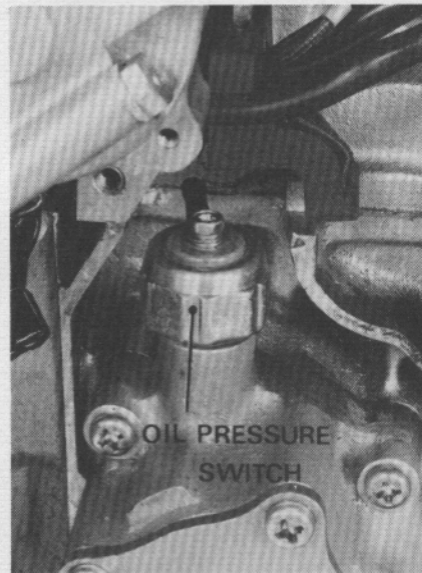



OIL PUMP

OIL PUMP REMOVAL

NOTE

The oil pump can be removed with the engine mounted in the frame.

Remove the oil drain plug and drain the oil from the engine (Page 2-2).
 Remove the gearshift arm from the spindle.
 Remove the left crankcase rear cover.

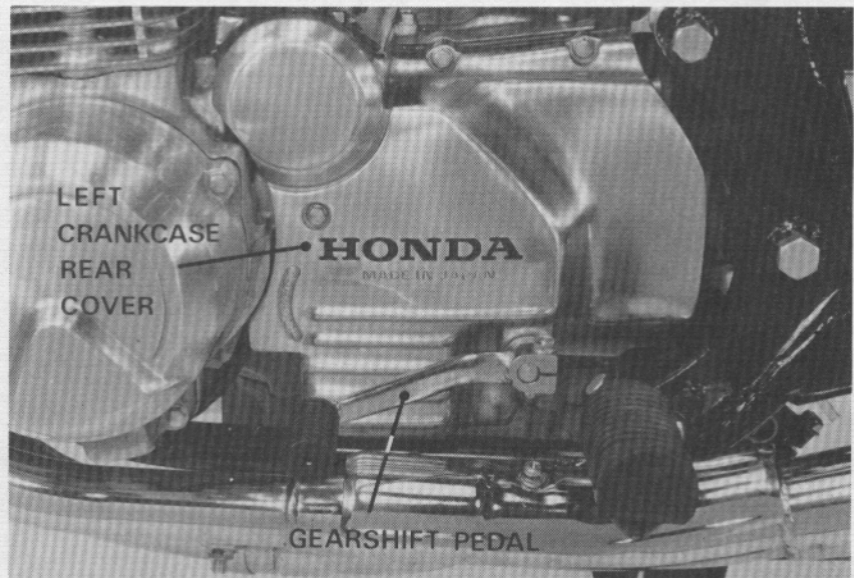

Disconnect the oil pressure switch wire.
 Remove the oil pressure switch.
 Remove the oil pump.

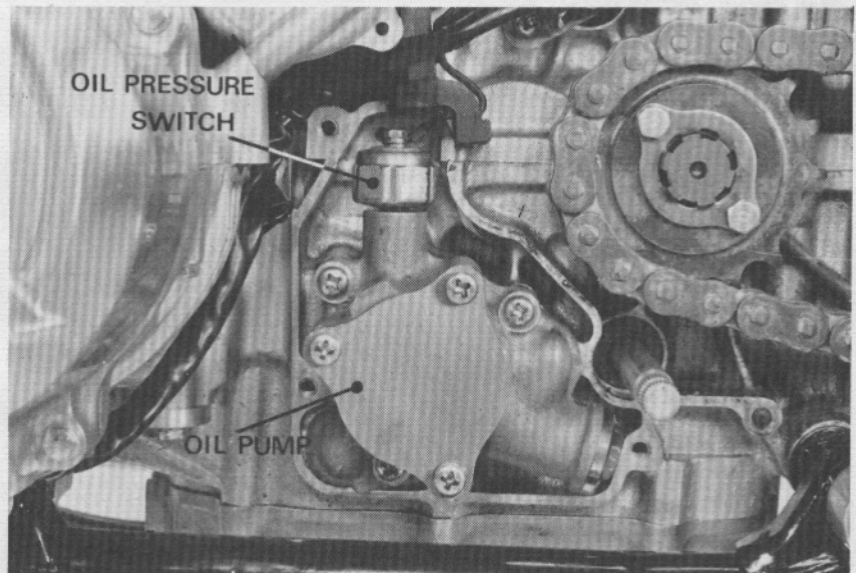

PRESSURE RELIEF VALVE DISASSEMBLY/ASSEMBLY

Remove the sealing bolt and O-ring.
 Remove the pressure relief valve spring and valve.

Check the relief valve, spring and O-ring for damage.
 Install the pressure relief valve, spring, O-ring and sealing bolt.

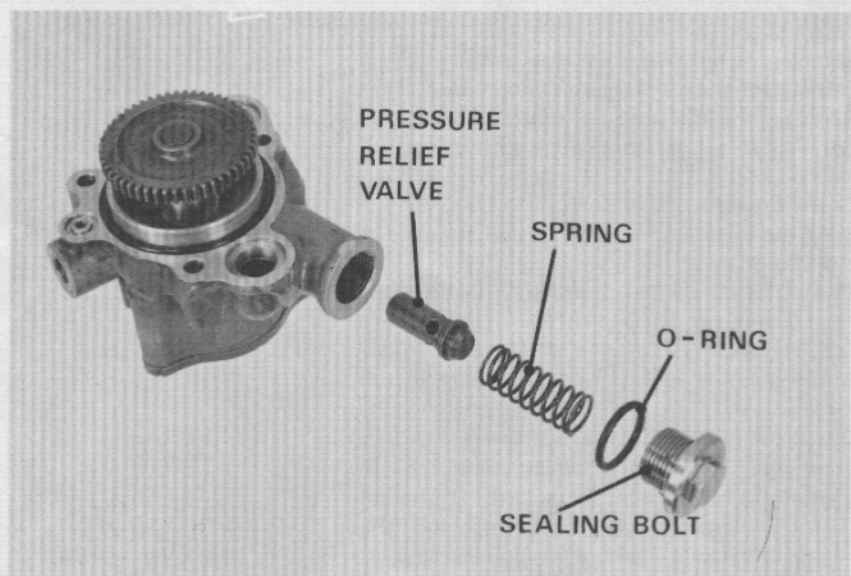



OIL PUMP INSPECTION

Remove the oil pump body cover.

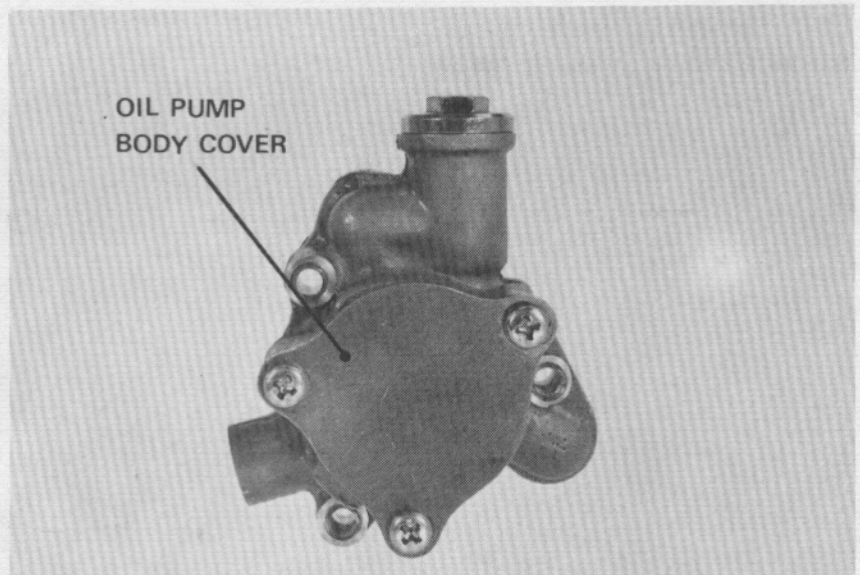

Measure the rotor tip clearance.

SERVICE LIMIT: 0.15 mm (0.006 in)

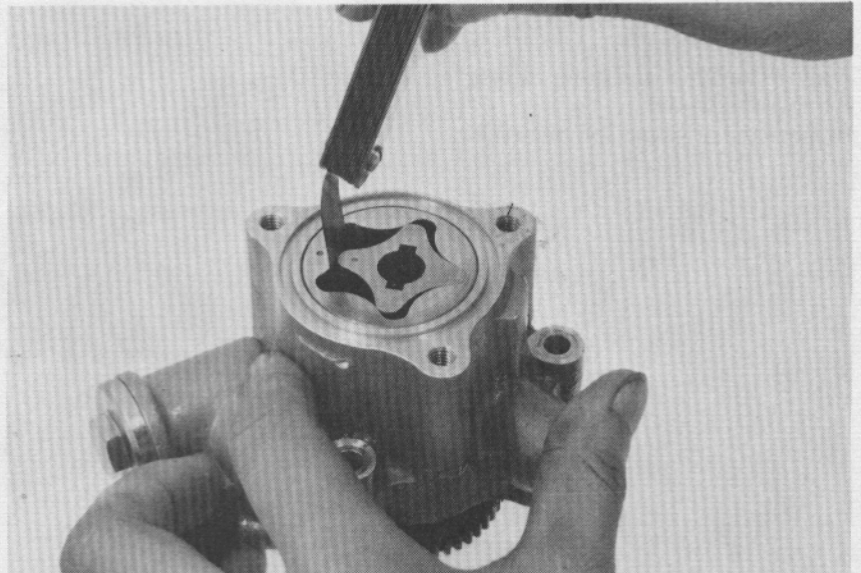

Measure the pump body clearance.

SERVICE LIMIT: 0.35 mm (0.014 in)

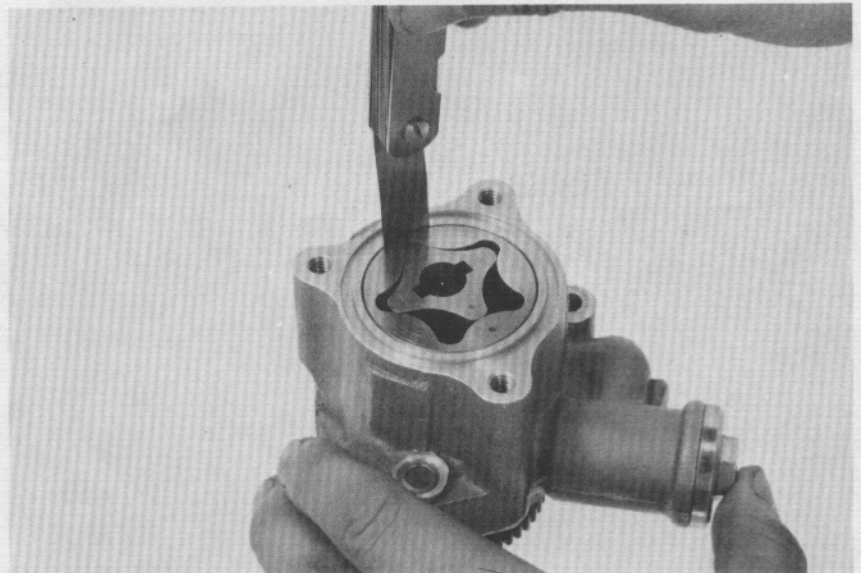



Measure the pump end clearance.

SERVICE LIMIT: 0.1 mm (0.004 in)

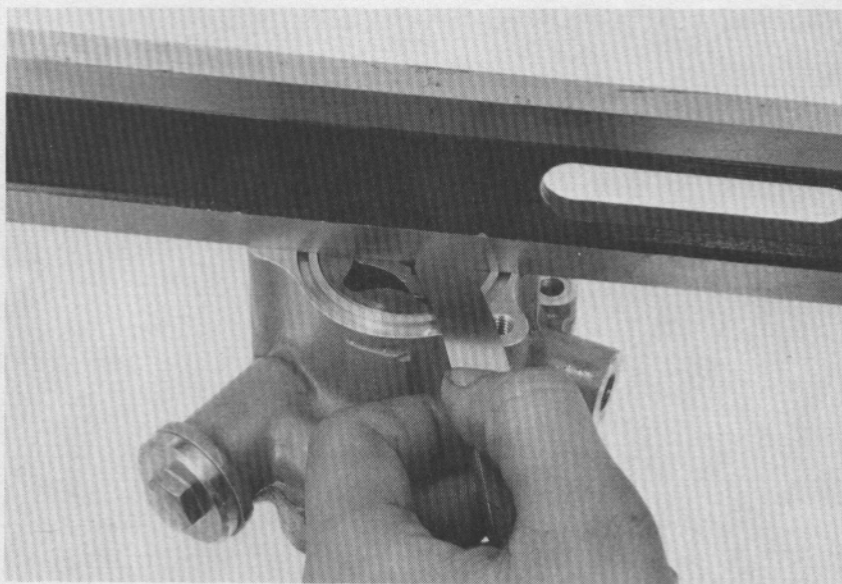

OIL PUMP DISASSEMBLY

- Remove the inner and outer rotors.
- Remove the O-rings.
- Remove the drive pin and drive shaft.

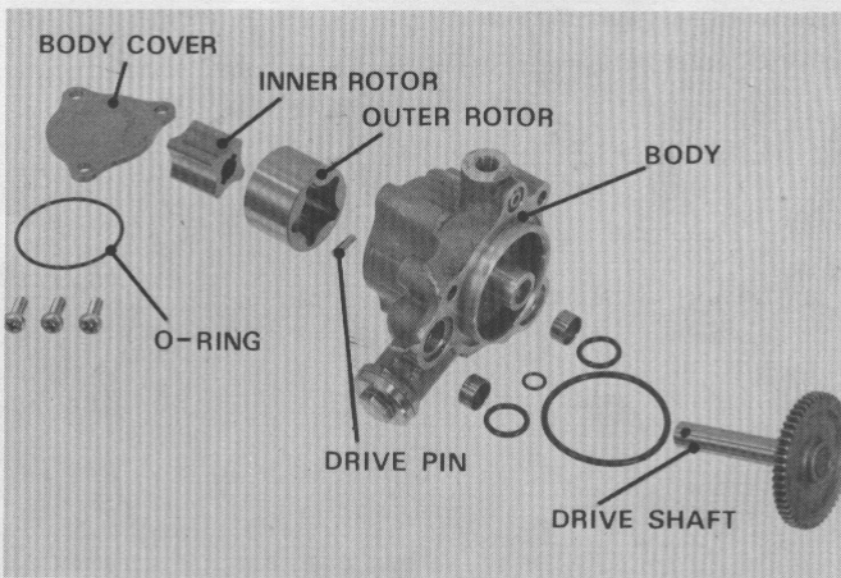
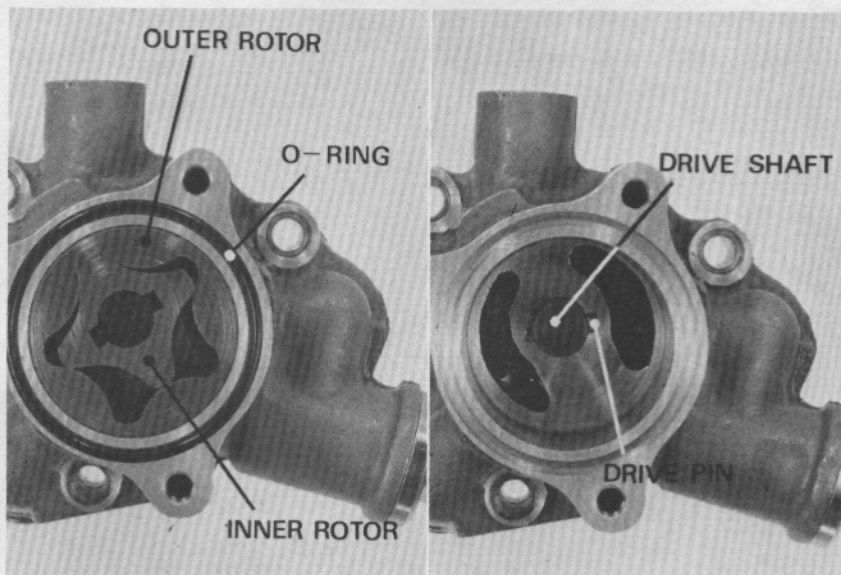



OIL PUMP ASSEMBLY

Insert the drive shaft.
Insert the drive pin into the drive shaft.
Parallel the drive pin with the square boss on the pump body.

Install the inner and outer rotors aligning their punch marks and the inner rotor with the drive pin.
Install the O-ring in the pump body groove.
Install the pump body cover.

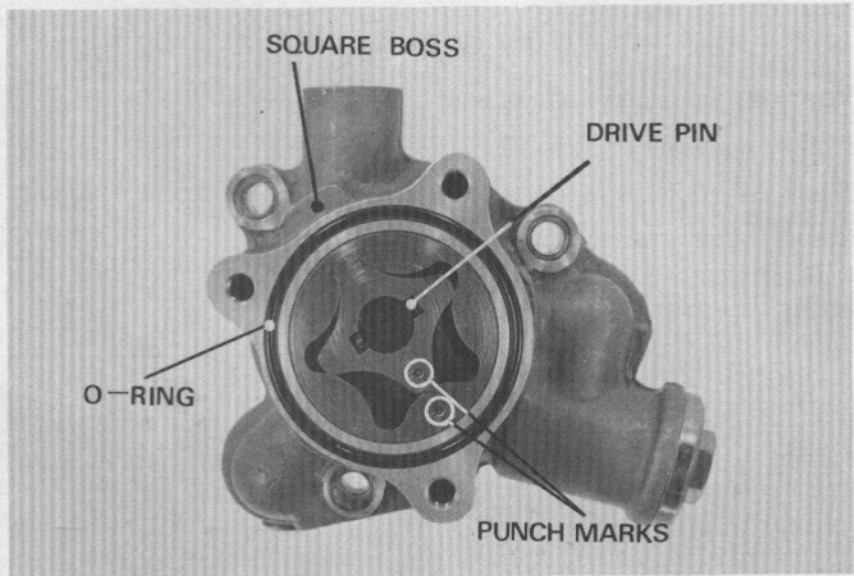

OIL PUMP INSTALLATION

Remove the oil control orifice from the crankcase oil hole and check that it is not clogged.
Install the orifice into the crankcase oil hole.

NOTE

Note the oil control orifice direction.

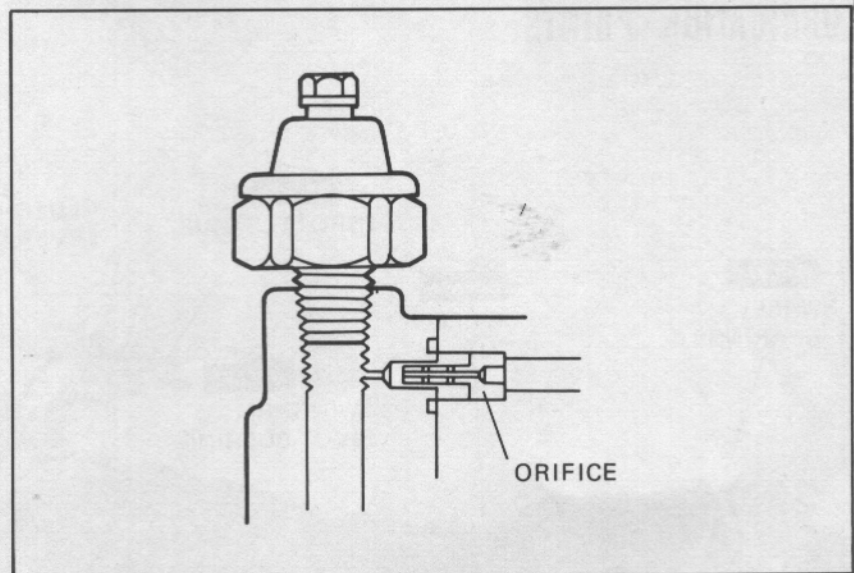

Install the O-rings and collars.

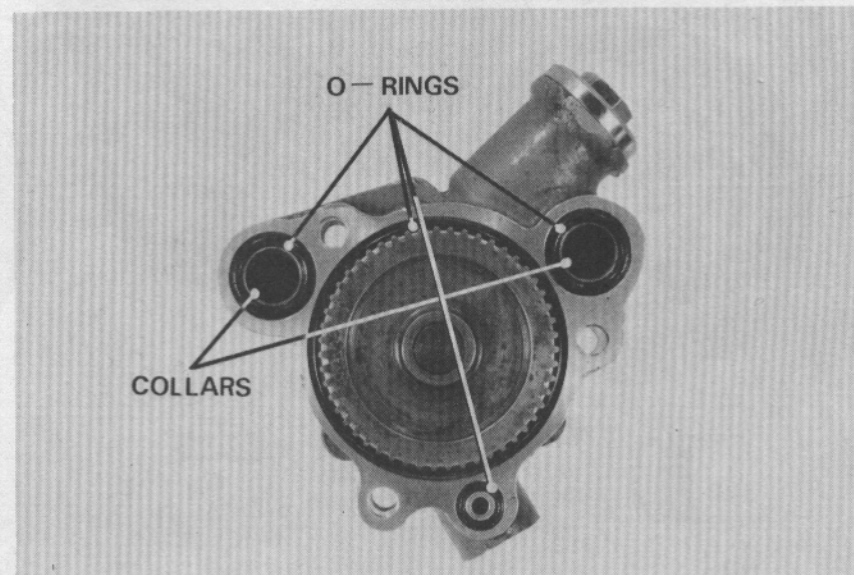



Install the oil pump.
Apply a liquid sealant to the oil pressure switch threads and install.

TORQUE: 1.0–2.0 kg-m (7–15 ft-lb)

Connect the pressure switch wire.

Install the left crankcase rear cover and gear-shift pedal.

Fill the crankcase with the recommended oil (See Page 2–2).

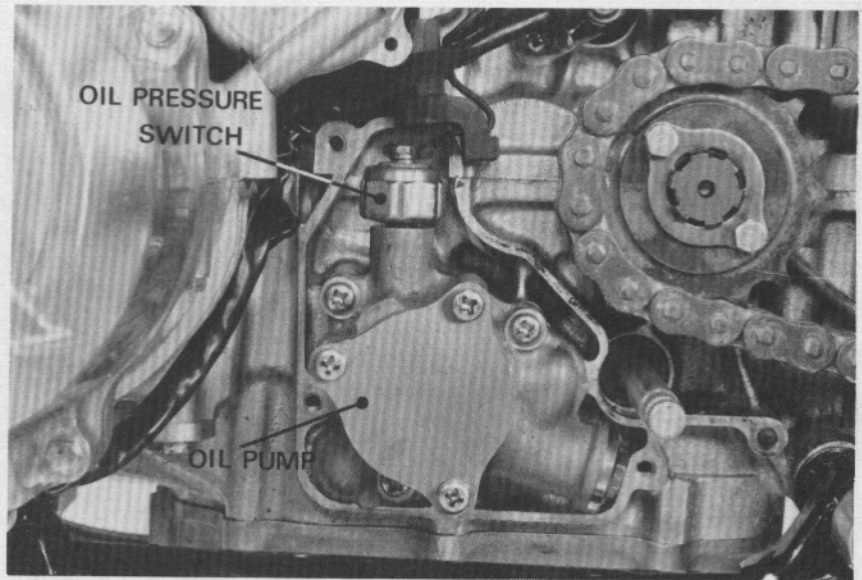

LUBRICATION POINTS

