



SERVICE INFORMATION	12-1
TROUBLESHOOTING	12-1
CONNECTING ROD REMOVAL	12-2
BEARING INSPECTION	12-3
BEARING SELECTION	12-5
CONNECTING ROD INSTALLATION	12-7

SERVICE INFORMATION

GENERAL INSTRUCTIONS

- All bearing inserts are select fit and are identified by color code. Select replacement bearings from the code tables.
- After installing new bearings, recheck them with plastigauge to verify clearance.
- Apply molybdenum disulfide grease to the main journals and crankpins during assembly.

TORQUE VALUES

Connecting rod	2.4–2.8 kg-m (17–20 ft-lb)
Crankshaft	2.2–2.6 kg-m (16–19 ft-lb)

SPECIFICATIONS

ITEM		STANDARD	SERVICE LIMIT
Crankshaft	Connecting rod big end side clearance	0.12–0.27 mm (0.005–0.011 in)	0.35 mm (0.014 in)
	Runout	—	0.05 mm (0.002 in)
	Crankpin oil clearance	0.018–0.047 mm (0.0007–0.0019 in)	0.08 mm (0.003 in)
	Main journal oil clearance	0.020–0.048 mm (0.0008–0.0019 in)	0.08 mm (0.003 in)
Cam chain	Length	184.87–184.90 mm (7.279–7.280 in)	186.4 mm (7.34 in)
Primary chain	Length	114.15–114.40 mm (4.494–4.504 in)	115.5 mm (4.55 in)

TROUBLESHOOTING

Excessive noise

1. Worn main journal bearing
2. Worn crankpin bearing



CONNECTING ROD REMOVAL

Separate the crankcase (Section 10).

Check the connecting rod side clearance.

SERVICE LIMIT: 0.35 mm (0.014 in)

Remove the bearing caps and rods.

NOTE

Mark the rods, bearings and bearing caps to indicate cylinder position, for installation.

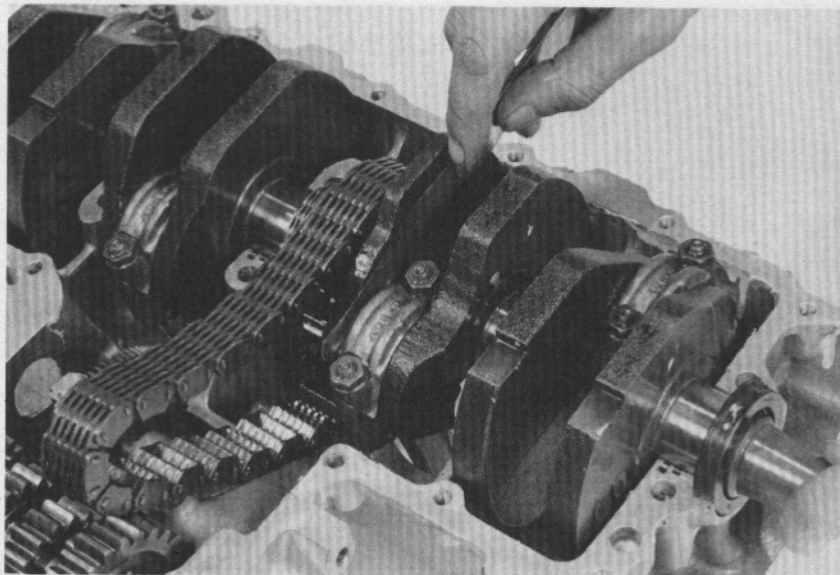

CRANKSHAFT INSPECTION

Remove the cam chain and primary chain.

Set the crankshaft on a stand or V blocks.

Set a dial indicator on the center main journal.

Rotate the crankshaft two revolutions and check the runout at the center journal.

SERVICE LIMIT: 0.05 mm (0.002 in)

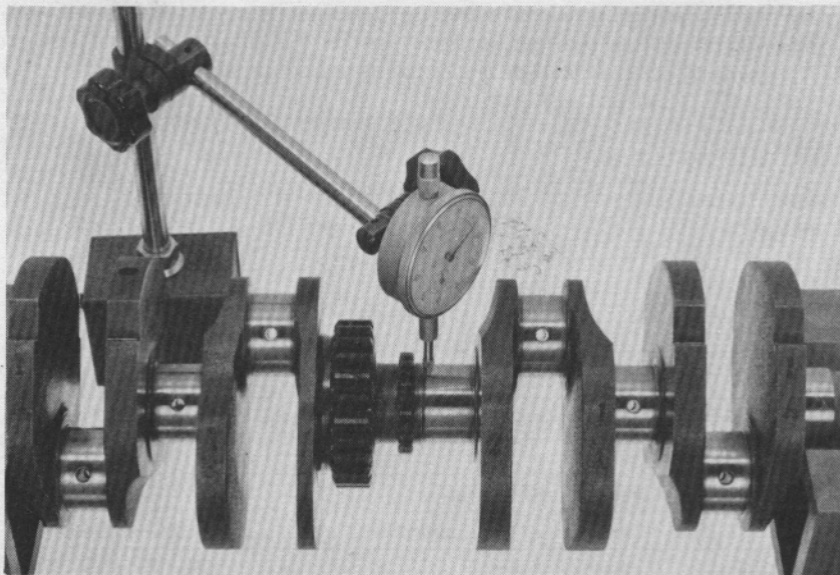

CAM CHAIN LENGTH MEASUREMENT

Place the cam chain over the cam and crankshaft sprockets.

Secure one sprocket. Apply 13 kg (29 lb) of tension to the other sprocket with a spring scale.

Measure the chain length as shown.

SERVICE LIMIT: 186.4 mm (7.34 in)

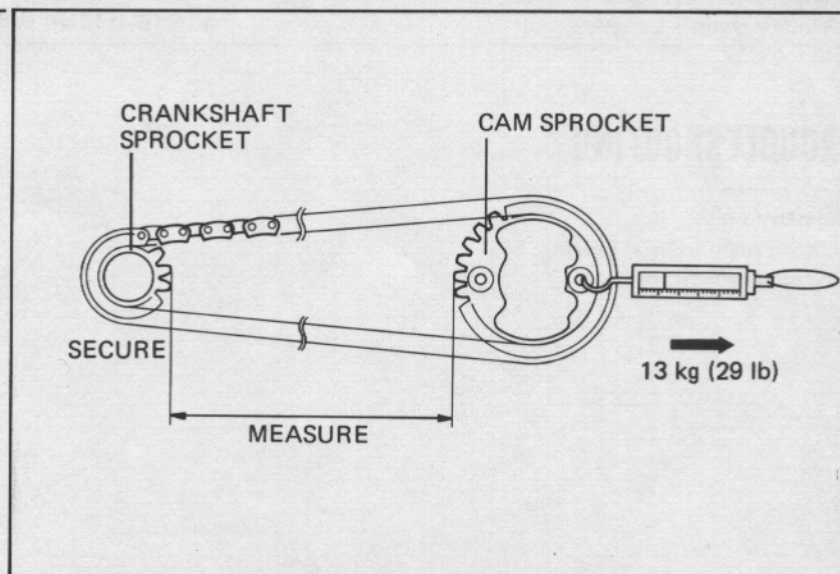



PRIMARY CHAIN LENGTH MEASUREMENT

Place the primary chain over the primary drive and driven gears. Secure one gear.

Apply 32 kg (71 lb) of tension to the other gear with a spring scale. Measure the chain length as shown.

SERVICE LIMIT: 115.5 mm (4.55 in)

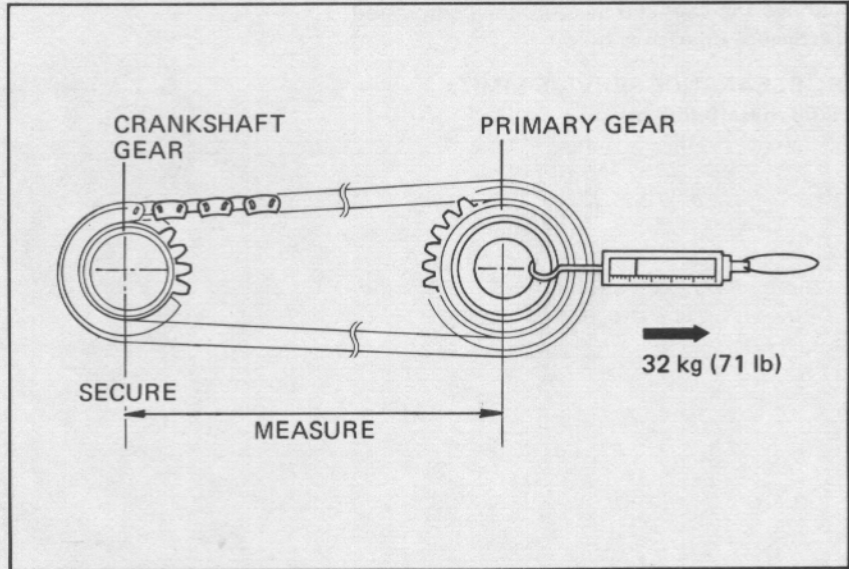

BEARING INSPECTION

CONNECTING RODS

Inspect the bearing inserts for damage or separation.

Clean all oil from the bearing inserts and crankpins.

Put a piece of plastigauge on each crankpin.

NOTE

Do not rotate the crankshaft during bearing inspection.

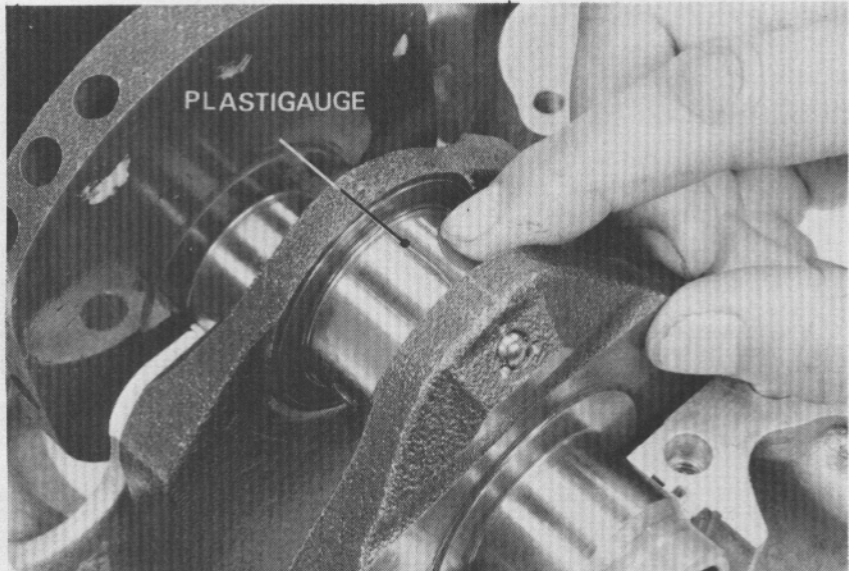

Install the bearing caps and rods on the correct crankpins, and tighten them evenly.

TORQUE: 2.4–2.8 kg-m (17–20 ft-lb)

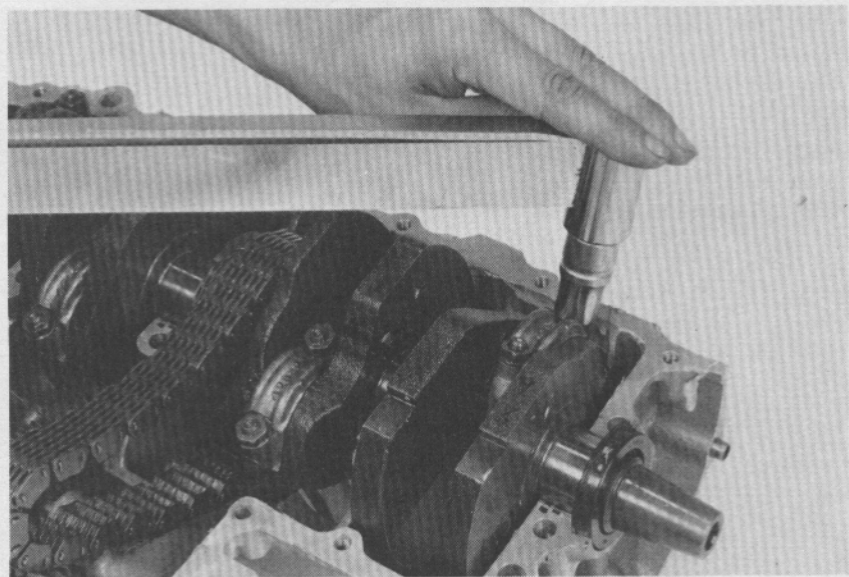



Remove the caps and measure the compressed plastigauge on each crankpin.

OIL CLEARANCE SERVICE LIMIT:
 0.08 mm (0.003 in)

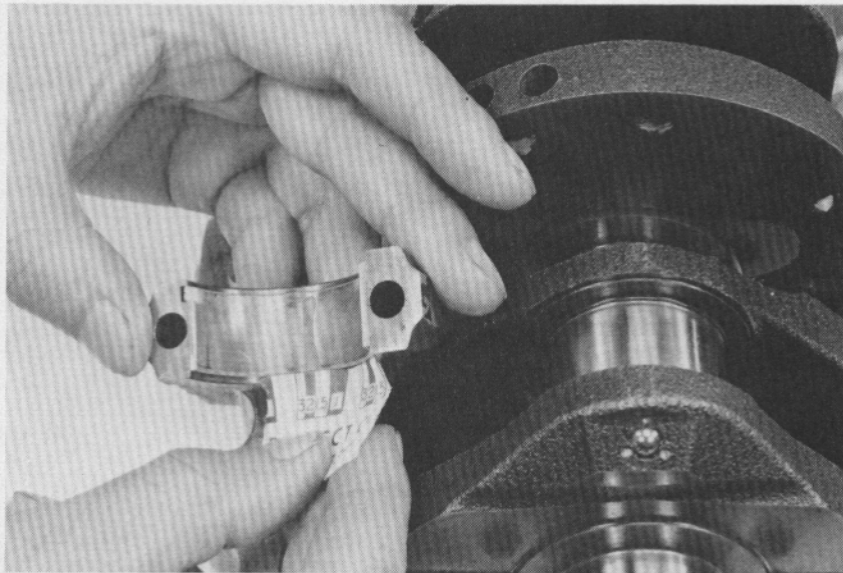

MAIN BEARINGS

Inspect the bearing inserts for damage or separation.

Clean all oil from the bearing inserts and journals.

Put a piece of plastigauge on each journal, avoiding the oil holes.

NOTE

Do not rotate the crankshaft during bearing inspection.

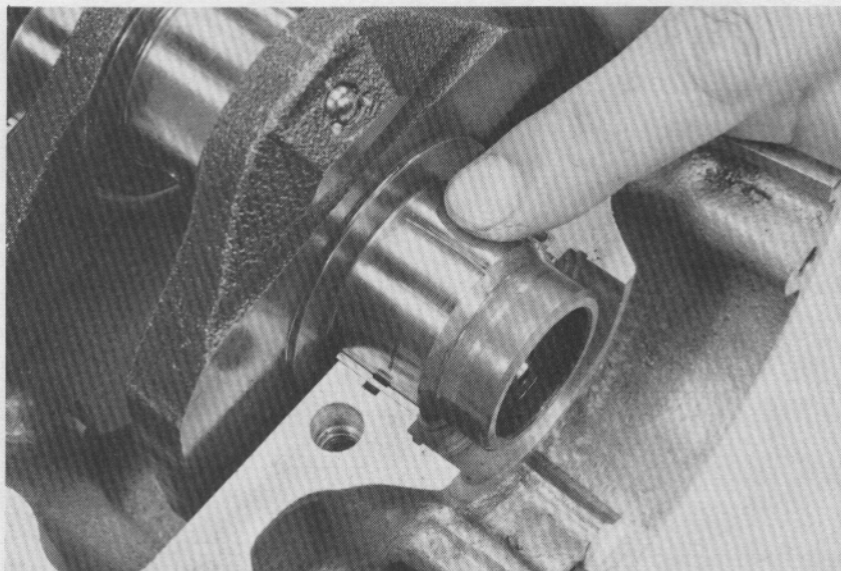

Install the main bearings on the correct journals of the upper crankcase. Tighten the bolts evenly in the sequence shown in 2-3 steps.

SPECIFIED TORQUES:

8 mm bolt (Crankshaft)
 2.2–2.6 kg-m (16–19 ft-lb)

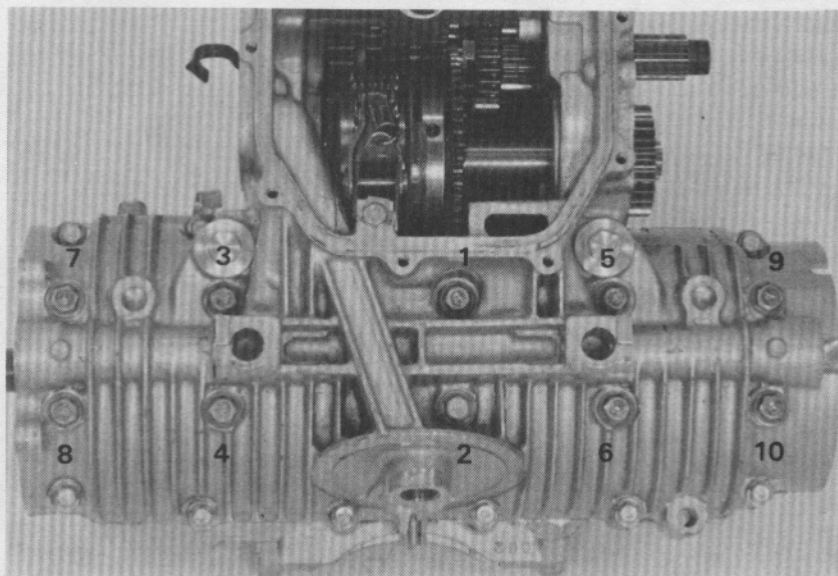



Remove the lower crankcase and measure the compressed plastigauge on each journal.

OIL CLEARANCE SERVICE LIMIT:
0.08 mm (0.003 in)

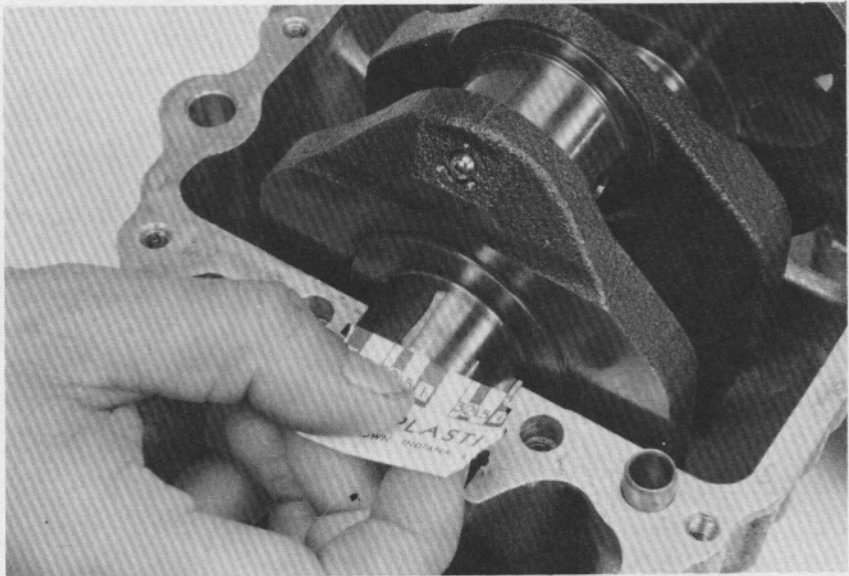

BEARING SELECTION

If rod bearing clearance is greater than the service limit, select replacement bearings as follows:

CONNECTING ROD BEARING INSERTS

Determine and record the corresponding rod I. D. code number.

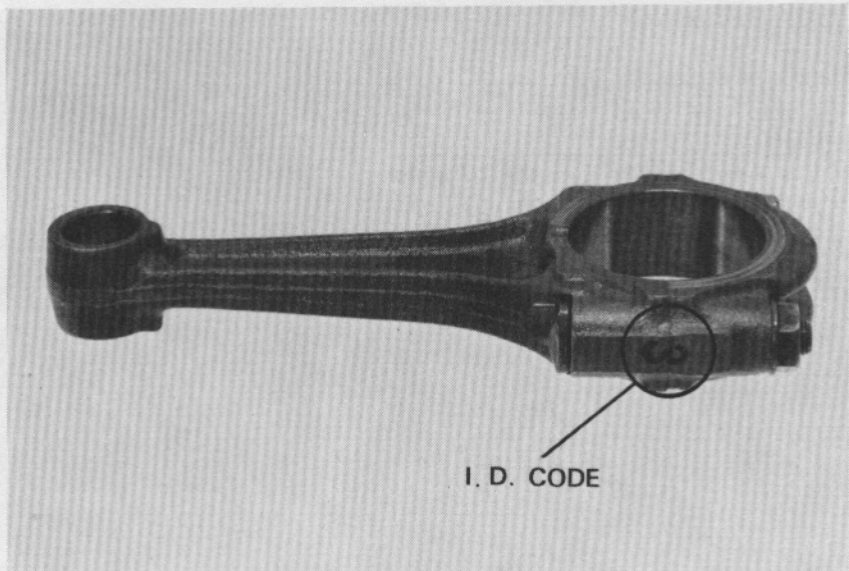

Determine and record the corresponding crankpin O. D. code (or measure the crankpin O. D.).

NOTE

The letter A or B on each crankweight is the code for each crankpin O. D.

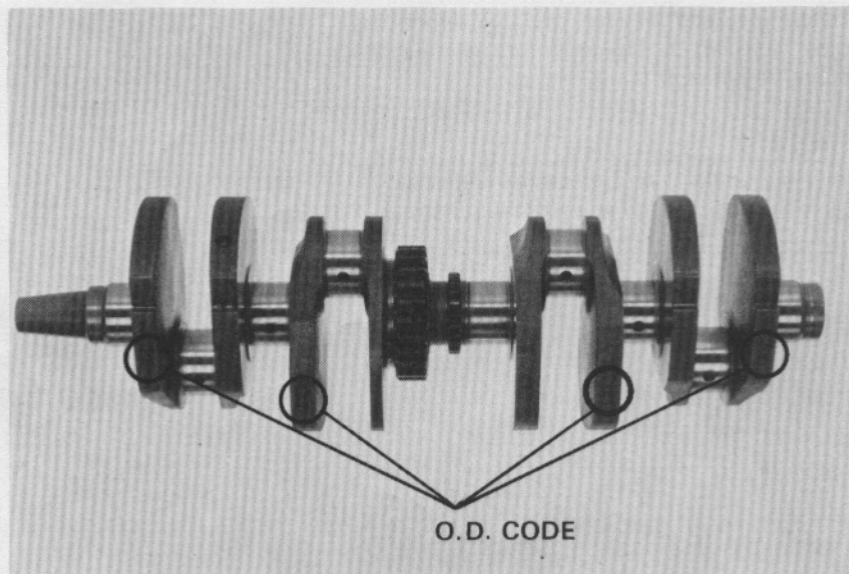



Cross reference the crankpin and rod codes to determine the replacement bearing color.

		CRANKPIN O. D. CODE		
		A	B	
		34.996– 35.006 mm	34.986– 34.996 mm	
CONNECTING ROD I. D. CODE	1	38.000– 38.007 mm	D (Yellow)	C (Green)
	2	38.007– 38.014 mm	C (Green)	B (Brown)
	3	38.014– 38.021 mm	B (Brown)	A (Black)

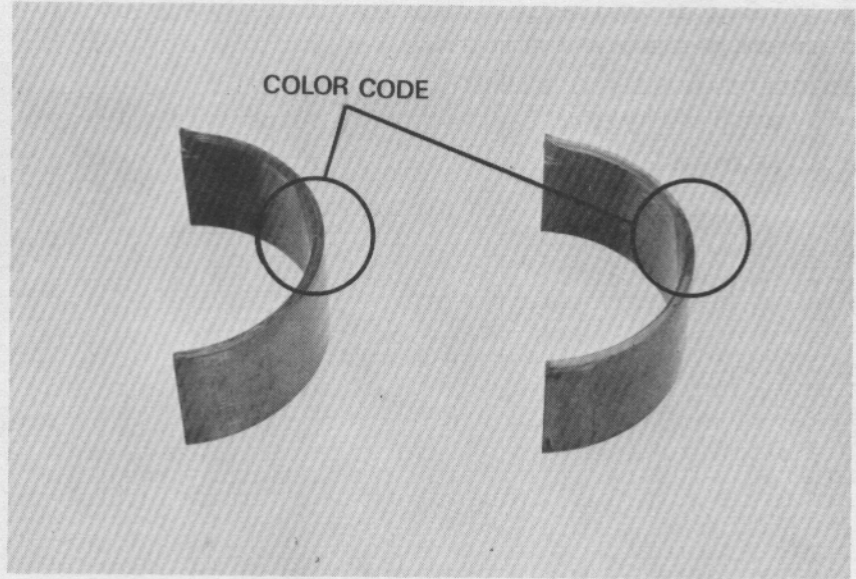

MAIN BEARING

Determine and record crankcase I. D. codes.

NOTE

The letter A, B or C on the lower rear crankcase is the code for the main journal I. D. from left to right; I. D. code for the third main journal is A.

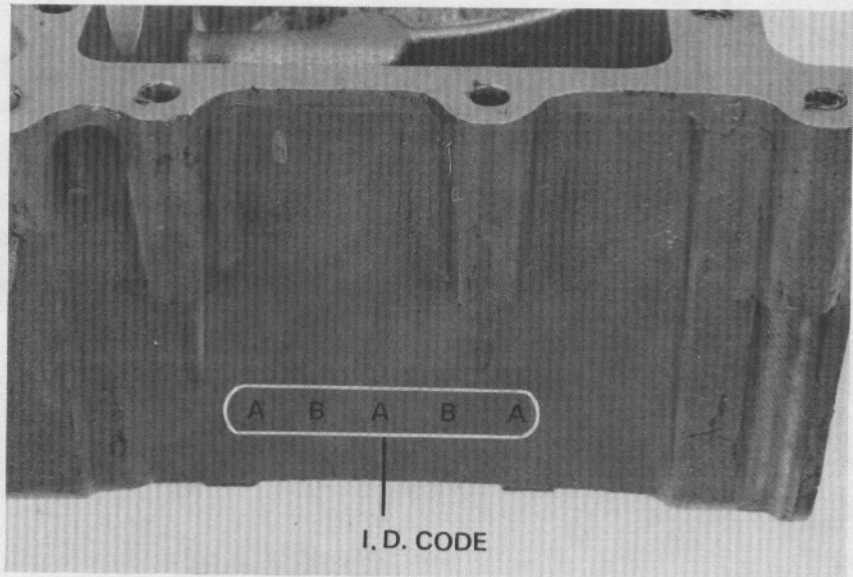

Determine and record the corresponding main journal O. D. code (or measure the main journal O. D.).

NOTE

The number 1 or 2 on each crankweight is the code for the adjacent main journal O.D.

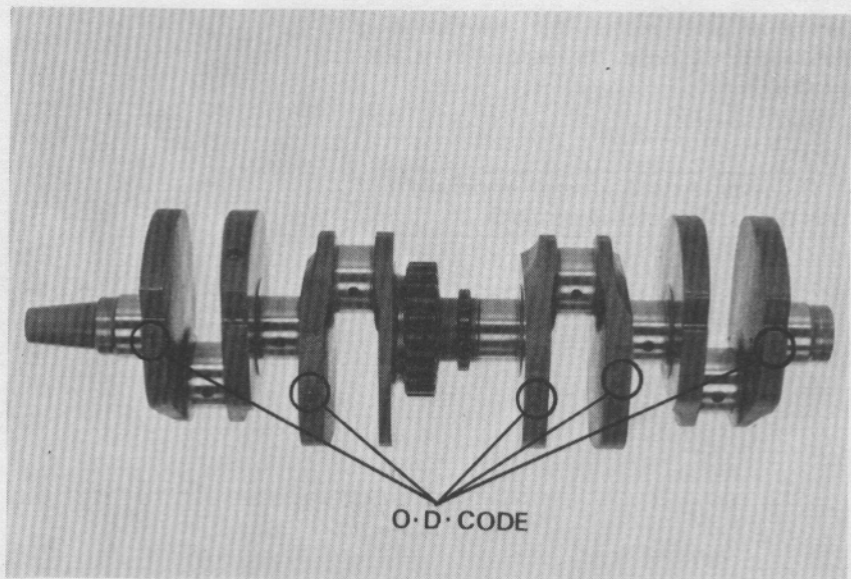



		MAIN JOURNAL O. D. CODE	
		1	2
CASE I. D. CODE	A	36.000— 36.008 mm	D (Yellow) C (Green)
	B	36.008— 36.016 mm	C (Green) B (Brown)
	C	36.016— 36.024 mm	B (Brown) A (Black)

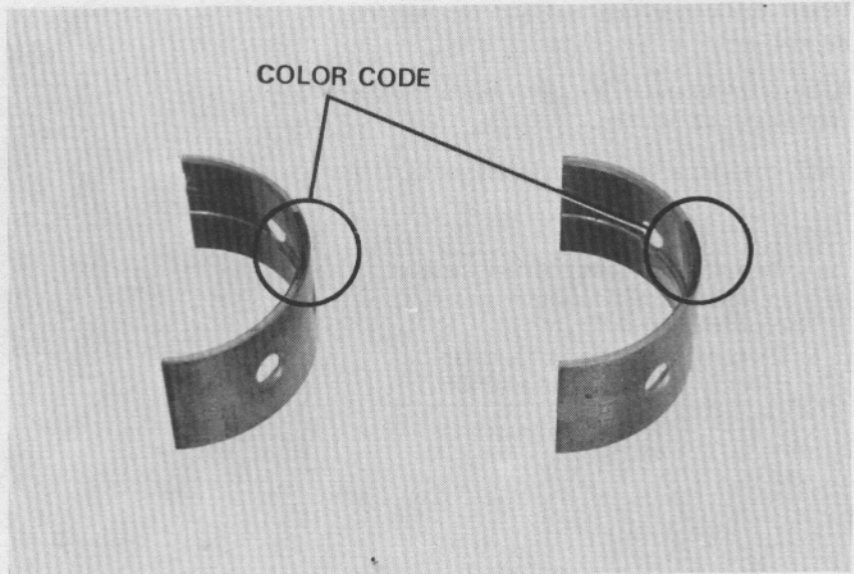

CONNECTING ROD INSTALLATION

Install the main bearings into the upper crankcase.

Apply molybdenum disulfide grease to the upper and lower main bearings.

Install the crankshaft with the cam chain and primary chain.

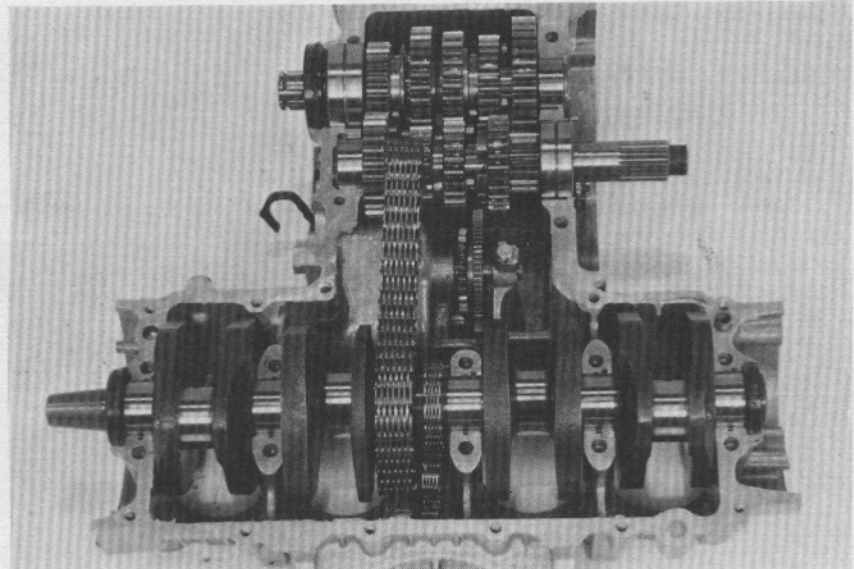

Before installing the connecting rods, make sure that the weight code combination is properly made.

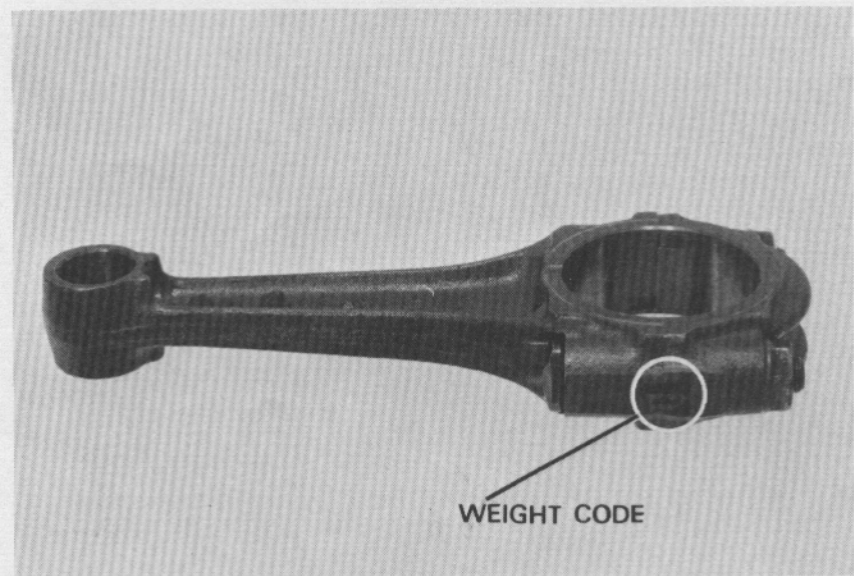
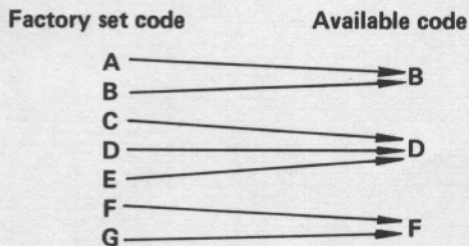



Install the connecting rod and cap bearing inserts.

Apply molybdenum disulfide grease to the connecting rod bearings.

Install the connecting rods and bearing caps.

NOTE

- Be sure connecting rods are installed in their correct position and I. D. code to the front.
- Cross reference the rod and cap I. D. codes to insure original assembly.

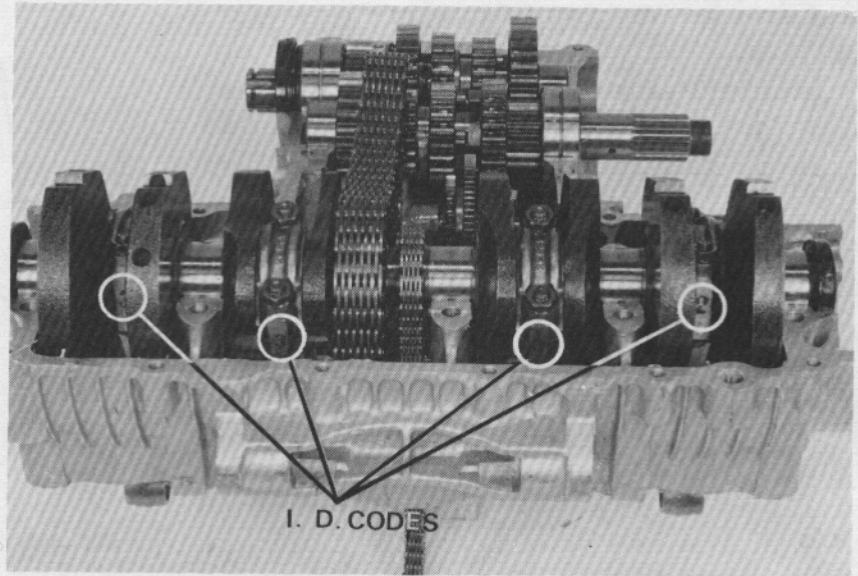

Tighten the connecting rod bearing cap bolts.

TORQUE: 2.4–2.8 kg-m (17–20 ft-lb)

NOTE

- Tighten the rod bearing cap bolts in two or more steps.
- After tightening the bolts, check that the rod moves freely without binding.

