



SERVICE INFORMATION	16-1
TROUBLESHOOTING	16-2
BATTERY	16-3
CHARGING SYSTEM	16-4
A. C. GENERATOR REMOVAL/ INSTALLATION	16-5
VOLTAGE REGULATOR	16-8

## SERVICE INFORMATION

### GENERAL INSTRUCTIONS

- Battery fluid level should be checked regularly. Fill with distilled water as necessary.
- Quick charge the battery, only in an emergency. Slow-charging is preferred.
- Remove the battery from the motorcycle for charging. If the battery must be charged on the motorcycle, disconnect the battery cables.

**WARNING**

*Do not smoke or have flames near a charging battery. The gas produced by a battery is highly flammable and can explode.*

- All charging system components can be tested on the motorcycle.

### SPECIAL TOOL

Common tool  
Rotor puller                    07733-0020001

### TORQUE VALUE

A.C. generatar                    5.0-6.0 kg-m (36-43 ft-lb)

### SPECIFICATIONS

Battery	Capacity	12V 12 AH	
	Specific gravity	1.270-1.290/20°C (68°F)	
	Charging rate	1.4 amperes maximum	
A.C. generator	Capacity	1,500 rpm	5,000 rpm
		6.5A min.	18A min.
Voltage regulator	Transistorized non-adjustable regulator		



## TROUBLESHOOTING

### No power — key turned on:

1. Dead battery
  - Low fluid level
  - Low specific gravity
  - Charging system failure
2. Disconnected battery cable
3. Main fuse burned out
4. Faulty ignition switch

### Low power — key turned on:

1. Weak battery
  - Low fluid level
  - Low specific gravity
  - Charging system failure
2. Loose battery connection

### Low power — engine running:

1. Battery undercharged
  - Low fluid level
  - One or more dead cells
2. Charging system failure

### Intermittent power:

1. Loose battery connection
2. Loose charging system connection
3. Loose starting system connection
4. Loose connection or short circuit in ignition system
5. Loose connection or short circuit in lighting system

### Charging system failure:

1. Loose, broken, or shorted wire or connection
2. Faulty voltage regulator
3. Faulty silicon rectifier
4. Faulty A.C. generator



**BATTERY**  
**REMOVAL**

Remove the right and left side covers.  
Disconnect the ground cable at the battery terminal.  
Disconnect the positive cable at the starter relay switch terminal.  
Remove the battery holder.

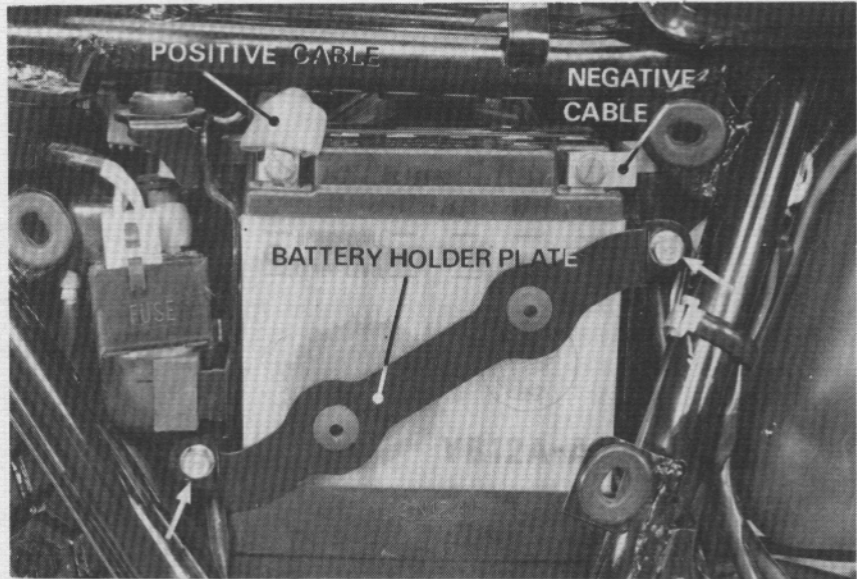

**TESTING SPECIFIC GRAVITY**

Test each cell with a hydrometer.

**SPECIFIC GRAVITY:**  
(20°C, 68°F)

1.270–1.290	Fully charged
Below 1.260	Under charged

**NOTE**

- The battery must be recharged if the specific gravity is below 1.230.
- The specific gravity varies with the temperature as shown in the table.
- Replace the battery if sulfation is evident or if the space below the cell plates is filled with sediment.

**WARNING**

*The battery contains sulfuric acid. Avoid contact with skin, eyes, or clothing. Antidote: Flush with water and get prompt medical attention.*

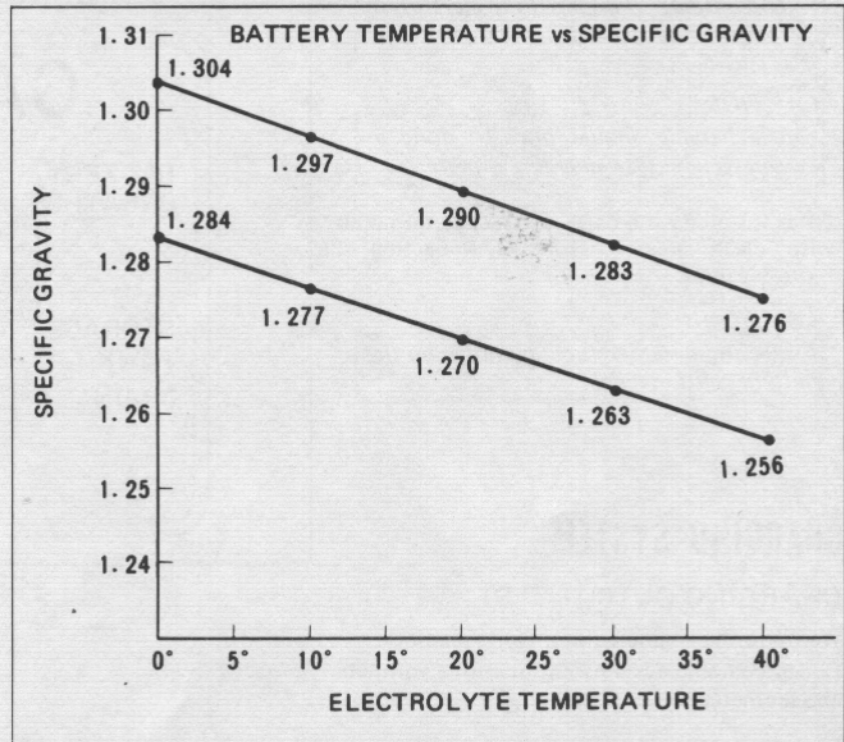

Specific gravity changes by 0.007 for every 10°C.





### BATTERY CHARGING

Remove the battery cell caps.  
 Connect the charger positive (+) cable to the battery positive (+) terminal.  
 Connect the charger negative (-) cable to the battery negative (-) terminal.

#### Charging current:

1.4 amperes max.

#### Charging:

Charge the battery until specific gravity is 1.270–1.290 at 20°C (68°F).

#### WARNING

- Before charging a battery, remove the cap from each cell.
- Keep flames and sparks away from a charging battery.
- Turn power ON/OFF at the charger, not at the battery terminals.
- Discontinue charging if the electrolyte temperature exceeds 45°C (113°F).

#### CAUTION

Quick-charging should only be done in an emergency; slow-charging is preferred.

After installing the battery, coat the terminals with clean grease before re-connecting the battery cables.

#### CAUTION

Route the breather tube as shown on the battery caution label.

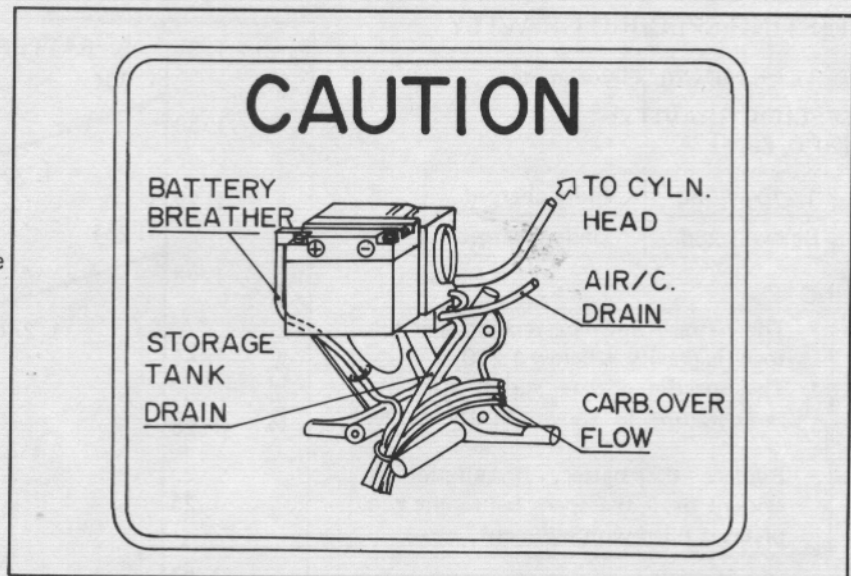
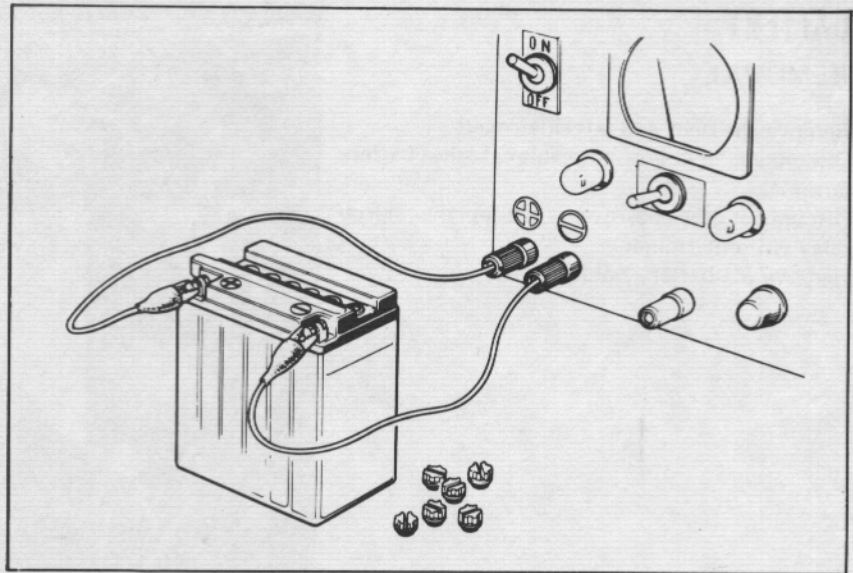

## CHARGING SYSTEM

### CHARGING OUTPUT TEST

Warm up the engine before taking readings.  
 Check charging system output with a voltmeter and ammeter.

#### NOTE

Use a fully charged battery to check the charging system output.

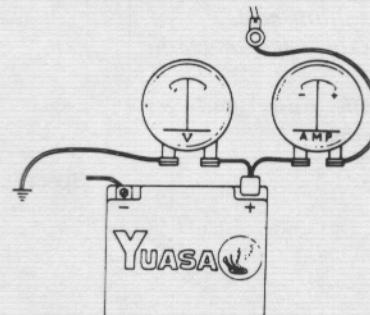

### TECHNICAL DATA

MAIN SWITCH	LIGHTING SWITCH	INITIAL CHARGING	AT 5,000 rpm
ON	ON (High beam)	1,650 rpm	0 amperes minimum/14 volts



## A.C. GENERATOR REMOVAL/ INSTALLATION

Remove the left side cover, raise the seat and disconnect the A.C. generator coupler and neutral and oil pressure switch wire coupler.

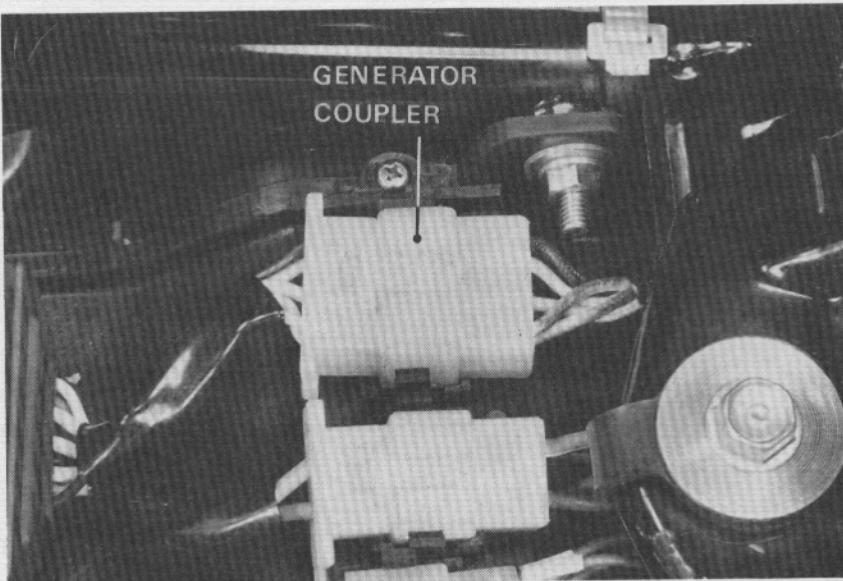

Remove three bolts and remove the A.C. generator cover.

Remove the left crankcase rear cover.

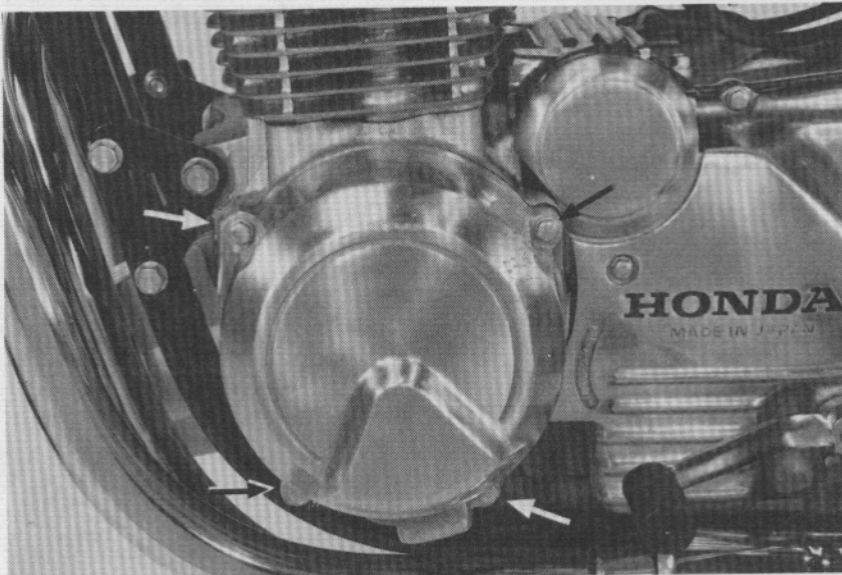

Remove five screws and remove the generator stator with the brush holder.

Shift the transmission into gear and apply the rear brake.

Remove the generator rotor bolt.

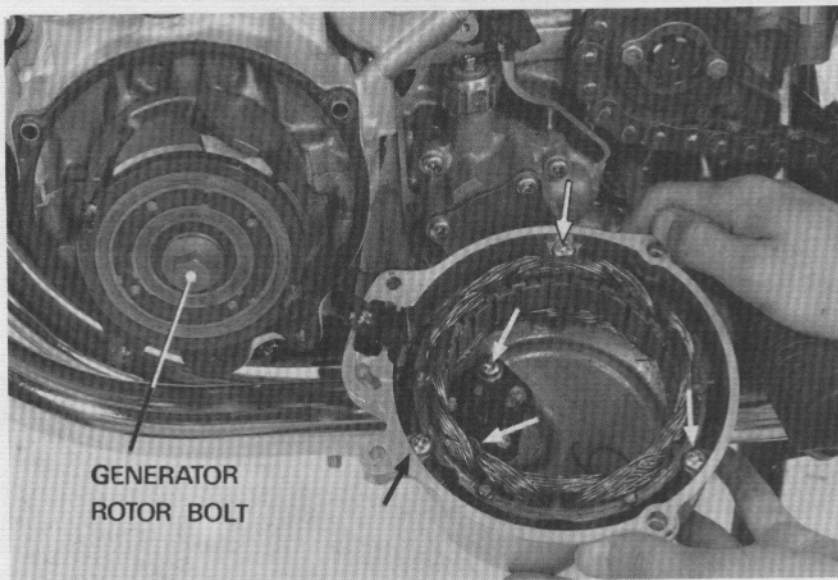





Remove the generator rotor while applying the rear brake.

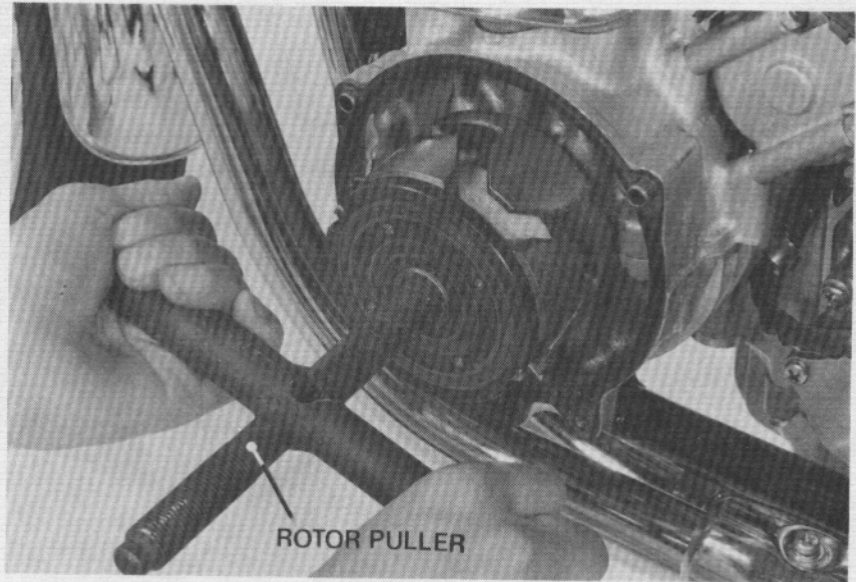

### GENERATOR INSPECTION

Inspect the length of each brush as shown.  
 If the brush is worn to the scribed service limit line, replace the brush.

**SERVICE LIMIT:** Scribed line



Remove and replace the brush with the mounting screws.

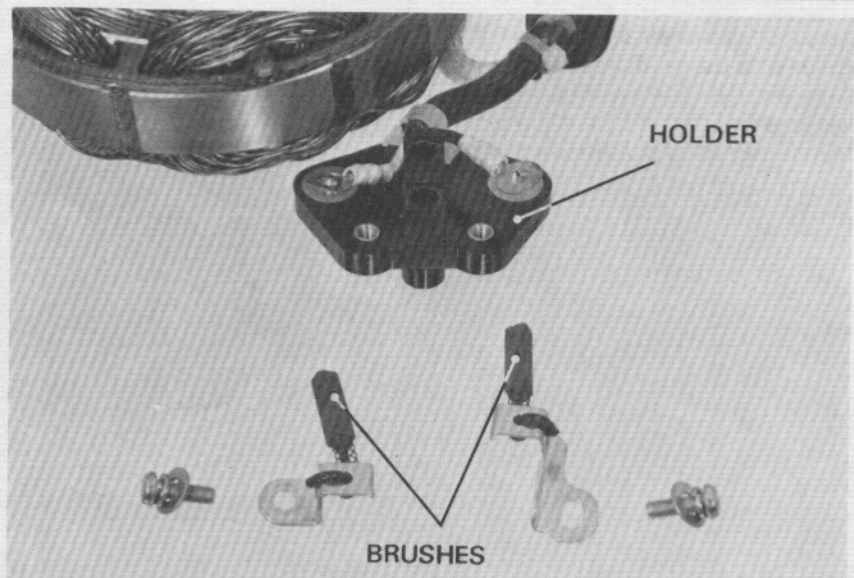



**STATOR COIL CONTINUITY TEST**

**NOTE**

It is not necessary to remove the stator to make this test.

Check the yellow leads to the A.C. generator stator for continuity with an ohm meter on the R x 1 scale. Replace the stator if any yellow lead is not continuous with the others, or if any lead has continuity to ground.

**SPECIFIED RESISTANCE: 0.41–0.51Ω**

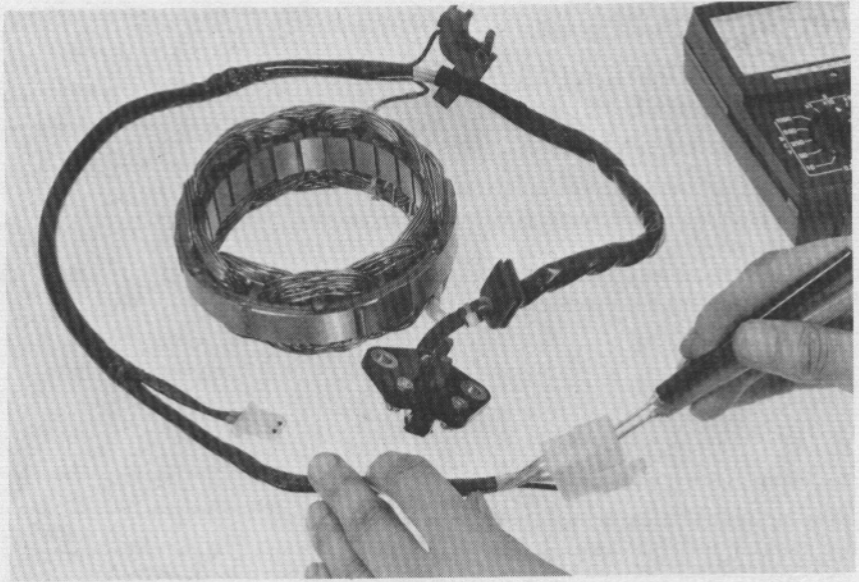

**INSTALLATION**

Install the generator rotor.

**TORQUE: 5.0–6.0 kg-m (36–43 ft-lb)**

Route the generator leads properly.

**CAUTION**

*Do not use washer to the brush holder mounting screws or the screw head will interfere with the generator rotor.*

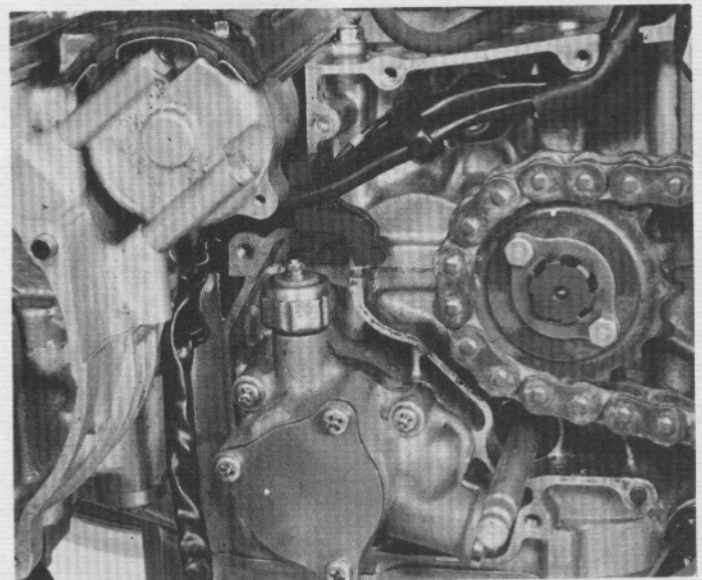
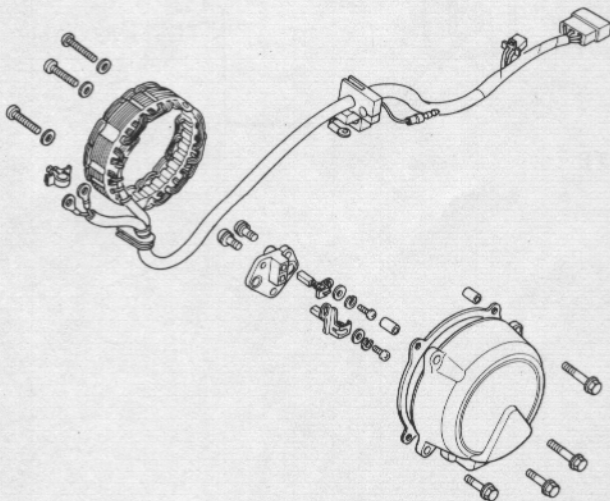
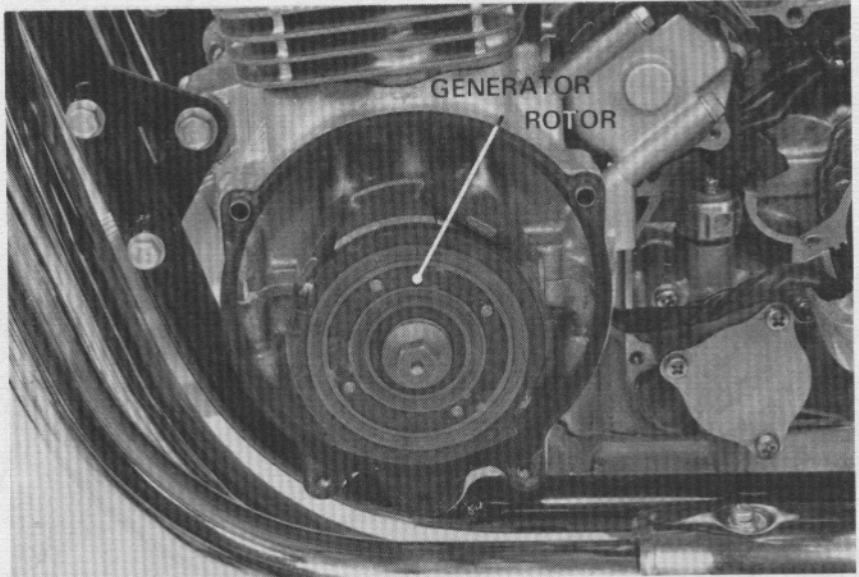



## VOLTAGE REGULATOR

### VOLTAGE REGULATOR PERFORMANCE TEST

#### a. Testing with a voltmeter

Connect a voltmeter across the battery.  
 Check regulator performance with the engine running.  
 Regulator must cut off the field coil current when battery voltage reaches 14–15V.

#### b. Testing with a variable resistor

Connect two 12V batteries in series.  
 Connect a variable resistor (0–100Ω) across the battery with a 50Ω resistor in between.  
 Test lamp must go out when voltage reaches 14–15V on the voltmeter by adjusting the variable resistor.

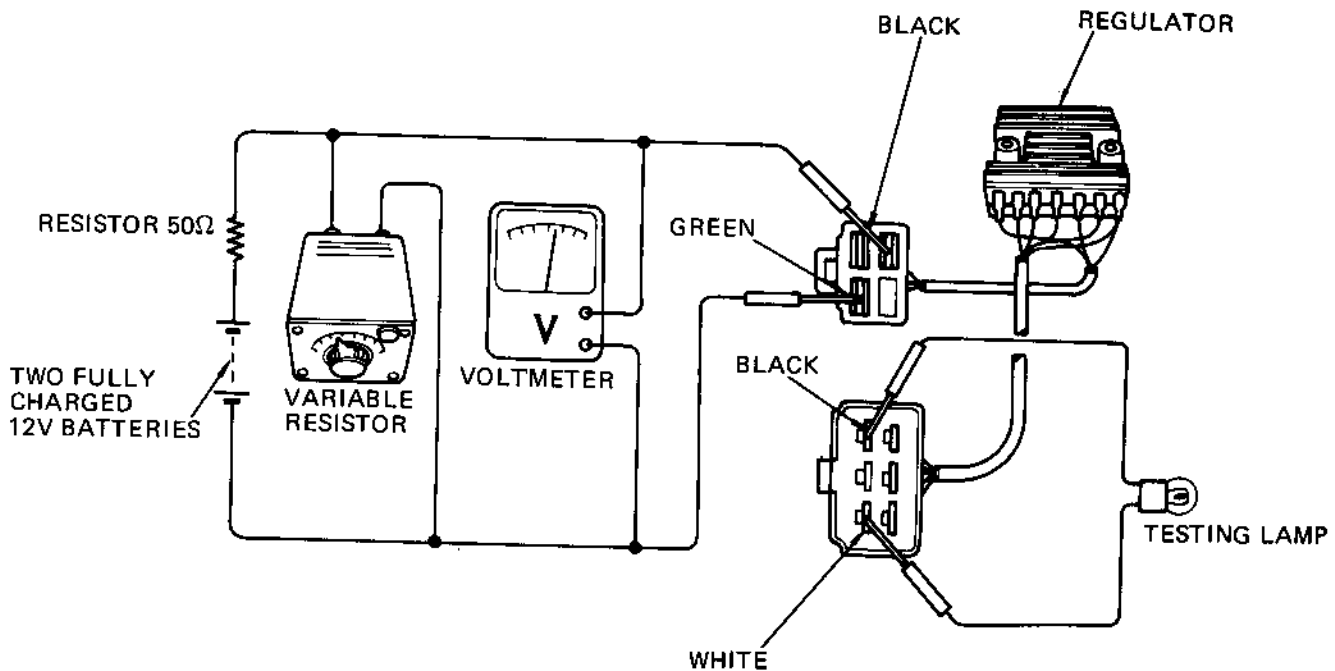
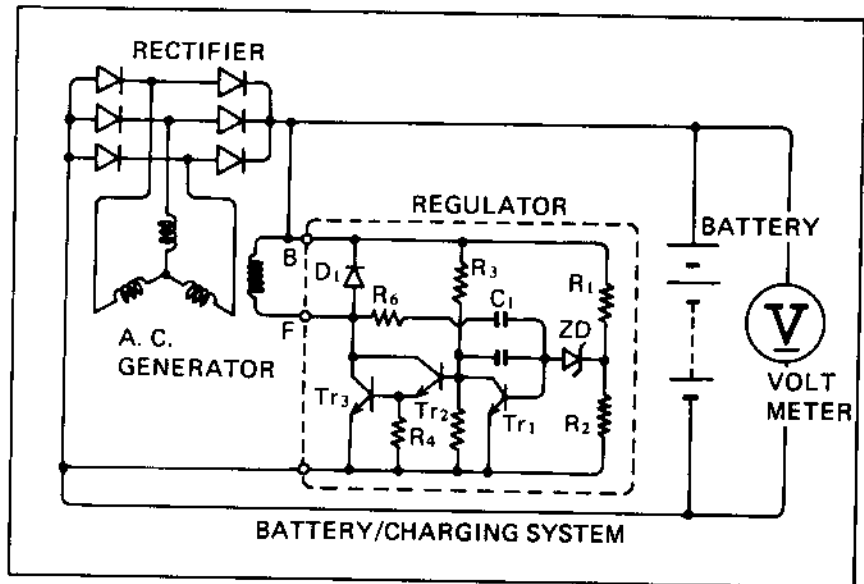





**VOLTAGE REGULATOR/  
RECTIFIER TEST**

Check the resistance between the leads with an ohmmeter.

**RESISTANCE IN NORMAL DIRECTION:**

- Green and any yellow: 5-40Ω
- Red/white and any yellow: 5-40Ω

**RESISTANCE IN REVERSE DIRECTION:**

- Red/white and any yellow: 2000Ωmin.
- Green and any yellow: 2000Ωmin.

